

**City Council Meeting
City Hall - Webster City, Iowa
August 2, 2021 - 6:00 p.m.**

**Council Members and minimal staff will be meeting
in the Council Chambers at City Hall.**

Due to the COVID-19 concerns and social distancing recommendations,
this meeting will be Open to the Public, with limited seating available
in the Council Chambers, and also by ELECTRONIC MEANS.

Iowa Code Section 21.8 outlines the guidelines to hold an electronic meeting when
there are valid concerns that an in-person meeting is "impossible or impractical".

Join Zoom Meeting

<https://us02web.zoom.us/j/82241362688>

Meeting ID: 822 4136 2688

One tap mobile

+13126266799,,82241362688# US (Chicago)

+16465588656,,82241362688# US (New York)

Dial by your location

+1 312 626 6799 US (Chicago)

+1 646 558 8656 US (New York)

+1 301 715 8592 US (Washington DC)

+1 346 248 7799 US (Houston)

+1 669 900 9128 US (San Jose)

+1 253 215 8782 US (Tacoma)

Meeting ID: 822 4136 2688

Find your local number: <https://us02web.zoom.us/u/kbbTLsi01N>

Join by Skype for Business

<https://us02web.zoom.us/skype/82241362688>

The meeting can also be accessed by visiting the City of Webster City Facebook page
where it will be live-streamed at <https://www.facebook.com/cityofwebstercity/> The
video will also be posted to our YouTube Channel.

ROLL CALL

Motion on Approval of Agenda

Pledge of Allegiance

A. PETITIONS – COMMUNICATIONS – REQUESTS

This is the time of the meeting that a citizen may address the Council on a matter not on
the Agenda. **(no more than five minutes per person)** Except in cases of emergency,
the City Council will not take any action at this meeting, but may ask the City Staff to
research the matter or have the matter placed on the Agenda for a future meeting.

City Council Meeting Agenda, August 2, 2021

- 1. **Public Information**
 - a. **PROCLAMATION – RR Safety Week**

B. MINUTES AND CLAIMS

The following items have been deemed to be non-controversial, routine actions to be approved by the Council in a single motion. If a Council member, or a member of the audience wishes to have an item removed from this list, it will be considered in its normal sequence on the Agenda.

- 1. **MINUTES** of July 19, 2021
- 2. **RESOLUTION** on Payroll for the period ending July 17, 2021 and paid on July 23, 2021.
- 3. **RESOLUTION** on Bills Approve Fund List

C. GENERAL AGENDA

- 1.A. **PUBLIC HEARING - 6:05 P.M.**
COUNCIL MEMORANDUM **ENG LETTER**

Public Hearing on the Proposed Plans and Specifications and Proposed Form of Contract and Estimate of Cost for Construction of 2021 HMA Street Improvement Project.

- a. **RESOLUTION** approving plans, specifications and form of contract for the proposed construction of the 2021 HMA Street Improvement Project.
- b. **RESOLUTION** awarding Contract for the 2021 HMA Street Improvement Project to Heartland Asphalt, Inc., Mason City, IA for the total amount, which includes Alternate, of \$882,202.83.

- 1.B. **PUBLIC HEARING – 6:05 P.M.**
COUNCIL MEMORANDUM **ORDINANCE** **MAP**

Public Hearing on the proposed amending of the Code of Ordinances of the City of Webster City, Iowa, by amending Chapter 50 pertaining to Zoning as it relates to Uses Permitted in the M-1 (Light Industrial) District.

- a. First Reading of a proposed Ordinance, an Ordinance amending the Code of Ordinances of the City of Webster City, Iowa, 2019 by amending Chapter 50 pertaining to Zoning as it relates to Uses Permitted in the M-1 (Light Industrial) District.

2. Recommend approval for issuance of Beer and Liquor Licenses by the Iowa Department of Commerce for the following:

- a. Class C Liquor License, Outdoor Service and Sunday Sales
Seneca Street Saloon, 919 Seneca Street
- b. Class C Liquor License and Sunday Sales
Lomita’s Mexican Restaurant, 500 Second Street

City Council Meeting Agenda, August 2, 2021

3. Third Reading of a proposed Ordinance, an **ORDINANCE** amending the Code of Ordinances of the City of Webster City, Iowa, 2019, by amending Article III to Chapter 20 pertaining to Hotel/Motel Tax Board in the City of Webster City, Iowa.

a. Pass and Adopt Ordinance pertaining to Hotel/Motel Tax Board

4. **COUNCIL MEMORANDUM RESOLUTION** approving **CHANGE ORDER NO. 5** to the 2020 713 2nd Street Façade Project with Westbrooke Construction, Urbandale, Iowa in the amount of \$134,370.00.

5. **COUNCIL MEMORANDUM RESOLUTION** authorizing the Mayor and City Clerk to enter into an **AGREEMENT** with Goodpaster Tree Service, Webster City, Iowa providing for 2021 Tree Stump Removal Services. **LIST**

6. **COUNCIL MEMORANDUM** Motion to approve Street Department Supervisor request for two Street Department Foreman and the Street Department Supervisor to attend the Public Works Expo in St. Louis, Missouri August 29, 2021 through September 1, 2021, leaving on August 28, 2021.

7. **COUNCIL MEMORANDUM** Motion on **REQUEST** from St. Thomas Aquinas Parish/Youth Group to close Des Moines Street between Bank Street and Water Street on Saturday, September 11, 2021 from 10 a.m. to 3:00 p.m. for a Car Show. (Car show scheduled from 11:00 a.m. to 3:00 p.m.)

D. REPORTS AND RECOMMENDATIONS OF OFFICERS, BOARDS AND COMMISSIONS

1. City Manager Reports **JUNE 2021**
2. City Financial Reports **JUNE 2021**
3. Council Committee Reports
4. Other reports and recommendations

E. OTHER ITEMS

1. City Attorney **UPDATE/REPORT** of 07-28-2021

F. Adjourn regular meeting

NOTE: The Council may act by motion, resolution or ordinance on items listed on the Agenda

**Proclamation
National Rail Safety Week**

WHEREAS, 1,889 rail grade crossing collisions resulted in 678 personal injuries and were responsible for 201 fatalities in the United States during 2020; and

WHEREAS, 1,088 trespassing incidents have occurred in the United States resulting in 532 pedestrians being killed and another 556 injured while trespassing on railroad property rights of way during 2020; and

WHEREAS, educating and informing the public about rail safety, reminding the public that railroad right of ways are private property, enhancing public awareness of the dangers associated with highway rail grade crossings, ensuring pedestrians and motorists are looking and listening while near railways, and obeying established traffic laws will reduce the number of fatalities and injuries; and

WHEREAS, the International Association of Chiefs of Police, National Operation Lifesaver, United States Department of Transportation, and all local, state, county, and railroad law enforcement officers, first responders, and railroad corporations commit to partnering together in an effort to educate at a national level all aspects of railroad safety, to enforce applicable laws in support of National Rail Safety Week;

THEREFORE, I, John Hawkins, Mayor, do hereby attest my full support proclaiming September 20th to 26th, 2021, National Rail Safety Week and I encourage all citizens to recognize the importance of rail safety education.



CITY COUNCIL MEETING MINUTES
Webster City, Iowa July 19, 2021 – 6:00 p.m.

The City Council met in regular session at the City Hall, Webster City, Iowa at 6:00 p.m. on July 19, 2021, upon call of the Mayor and the advance agenda. The meeting was called to order by Mayor John Hawkins and roll being called there were present in Council Chambers John Hawkins, Mayor, and the following Council Members: Matt McKinney, Brian Miller and Logan Welch. Council Member Katelin Hartmann was absent.

Iowa Code Section 21.8 outlines the guidelines to hold an electronic meeting when there are valid concerns that an in-person meeting is "impossible or impractical".

Due to the COVID-19 concerns and social distancing recommendations, this meeting was Open to the Public with limited capacity and by electronic means utilizing the Zoom Platform. Details were provided in using the Zoom platform either by joining through the web portal or by calling in to view or participate.

It was moved by McKinney and seconded by Welch to approve the agenda.
ROLL CALL: Hawkins, McKinney, Miller and Welch voting aye.

Mayor John Hawkins led the Pledge of Allegiance.

PETITIONS – COMMUNICATIONS – REQUESTS

Jonathan Perin, President of Perin Industries, Webster City, addressed the Council with some concerns on electrical outages that have been occurring at the business over the past months. He stated that this has caused not only equipment to be repaired and replaced but also costs in down time of production. Line Department Supervisor Adam Dickinson was present and informed Council they have been working to assist in finding the problem and are awaiting data from DGR so they can determine how to move forward.

PUBLIC INFORMATION

Mayor Hawkins invited those interested to attend the National Night Out scheduled for Tuesday, August 3rd at West Twin Park. There will be events for the whole family including food and entertainment.

MINUTES AND CLAIMS

It was moved by Miller and seconded by Welch that the following motion and Resolutions be approved and adopted collectively:

1. That the meeting minutes of July 6, 2021 be approved.
2. That Resolution No. 2021-145 approving Payroll for the period ending July 3, 2021 and paid on July 9, 2021 in the amount of \$200,325.96 be passed and adopted.
3. That Resolution No. 2021-146 approving bills paid in the amount of \$2,201,051.67 be passed and adopted.

ROLL CALL: McKinney, Miller, Welch and Hawkins voting aye.

GENERAL AGENDA

PUBLIC HEARINGS

1.A. July 19, 2021 at 6:05 p.m. in Council Chambers at City Hall, Webster City, Iowa being the time and place for a Public Hearing on an Application for Voluntary Annexation located West of the Corporate Limits of Webster City, Iowa the same was held. One written objection was received via email on July 16, 2021 at 3:10 p.m. from Doug and Pam Ryan, 1618 230th Street, Webster City, Iowa. Oral Objections were presented by Doug Ryan, 1618 230th Street; Gina Monroe, 942 Elm Street; and Mark Roberts, 2375 Beach Street, all of Webster City, Iowa.

City Council Meeting Minutes, July 19, 2021

Council Member Katelin Hartmann joined the meeting via Zoom at 6:19 p.m.

Prior to action taken on the following Resolution, Council discussed the specifics of the Annexation and consideration of the objections presented.

- a. It was moved by Miller and seconded by McKinney that Resolution No. 2021-147 assenting to the Annexation of Certain Real Estate to the City of Webster City, Iowa be passed and adopted.

ROLL CALL: Miller, Hartmann, Hawkins and McKinney voting aye.
Welch voting nay.

1.B. July 19, 2021 at 6:05 p.m. in Council Chambers at City Hall, Webster City, Iowa being the time and place for a Public Hearing on the Proposed Plans and Specifications and proposed Form of Contract and Estimate of Cost for the 2021 Bridge Repair Project, the same was held. No written objections were received and no oral objections were presented.

- a. It was moved by Miller and seconded by Welch that Resolution No. 2021-148 approving and confirming Plans, Specifications and Form of Contract and Estimate of Cost for the 2021 Bridge Repair Project be passed and adopted.

ROLL CALL: Welch, Hartmann, Hawkins, McKinney and Miller voting aye

- b. It was moved by Welch and seconded by Miller that Resolution No. 2021-149 approving Awarding of Contract for the 2021 Bridge Repair Project to Jasper Construction Services, Inc., Newton, IA in the amount of \$133,565.00 be passed and adopted.

ROLL CALL: Hartmann, Hawkins, McKinney, Miller and Welch voting aye.
Ken Wetzler, Public Works Director, provided a summary of the project.

1.C. July 19, 2021 at 6:05 p.m. in Council Chambers at City Hall, Webster City, Iowa being the time and place for a Public Hearing on the Proposed Plans and Specifications and proposed Form of Contract and Estimate of Cost for the 2021 River Street Water Main Project, the same was held. No written objections were received and no oral objections were presented.

- a. It was moved by Welch and seconded by Miller that Resolution No. 2021-150 approving and confirming Plans, Specifications and Form of Contract and Estimate of Cost for the 2021 River Street Water Main Project be passed and adopted.

ROLL CALL: Hawkins, McKinney, Miller, Welch and Hartmann voting aye.

- b. It was moved by Miller and seconded by McKinney that Resolution No. 2021-151 approving Awarding of Contract for the 2021 River Street Water Main Project to Wunsch Construction, Greene, IA in the amount of \$387,671.50 be passed and adopted.

ROLL CALL: McKinney, Miller, Welch, Hartmann and Hawkins voting aye.
Ken Wetzler, Public Works Director, provided details on the project.

1.D. July 19, 2021 at 6:05 p.m. in Council Chambers at City Hall, Webster City, Iowa being the time and place for a Public Hearing on the Proposed Plans, Specifications and Form of Contract and Estimate of Cost for the Edgewood Water Main Loop Project, the same was held. No written objections were received and no oral objections were presented.

- a. It was moved by Miller and seconded by Welch that Resolution No. 2021-152 approving and confirming Plans, Specifications and Form of Contract and Estimate of Cost for the Edgewood Water Main Loop Project be passed and adopted.

ROLL CALL: Miller, Welch Hartmann, Hawkins and McKinney voting aye.

City Council Meeting Minutes, July 19, 2021

- b. It was moved by Miller and seconded by McKinney that Resolution NO. 2021-153 approving Awarding of Contract for the Edgewood Water Main Loop Project to GM Contracting, Inc., Lake Crystal, MN in the amount of \$388,938.27 be passed and adopted.

ROLL CALL: Welch, Hartmann, Hawkins, McKinney and Miller voting aye.

Ken Wetzler, Public Works Director, informed Council that only one bid was received for this project, but Engineer felt was reasonable to accept and to move forward with project.

2. It was moved by Welch and seconded by Miller that the issuance of Beer and Liquor Licenses by the Iowa Department of Commerce be approved for the following:

- a. Class B Beer Permit, Class C Native Wine Permit and Sunday Sales
Leon's Pizza, 643 2nd Street

ROLL CALL: Hartmann, Hawkins, McKinney, Miller and Welch voting aye.

3. It was moved by Miller and seconded by Welch that request from RAGBRAI Committee to close 2nd Street from Prospect Street to Willson Avenue from 1 to 6 p.m. on Monday, July 26, 2021 to prepare for the RAGBRAI ride through Webster City on July 27, 2021 be approved. (This request is in addition to the previous Street Closure(s) request by the Committee)

ROLL CALL: Hawkins, McKinney, Miller, Welch and Hartmann voting aye.

4. It was moved by Miller and seconded by McKinney that Second Reading of a proposed Ordinance, an Ordinance amending the Code of Ordinances of the City of Webster City, Iowa, 2019, by amending Article III to Chapter 20 pertaining to Hotel/Motel Tax Board in the City of Webster City, Iowa be approved.

ROLL CALL: McKinney, Miller, Welch, Hartmann and Hawkins voting aye.

5. It was moved by McKinney and seconded by Miller that the Third Reading of a proposed Ordinance, an Ordinance amending the Code of Ordinances of the City of Webster City, Iowa, 2019, by Amending Chapter 48 Pertaining to Sewer Rental Rates be approved.

ROLL CALL: Miller, Welch, Hartmann, Hawkins and McKinney voting aye.

- a. It was moved by Welch and seconded by McKinney that Ordinance No. 2021-1846, an Ordinance amending the Code of Ordinances of the City of Webster City, Iowa, 2019, by Amending Chapter 48 Pertaining to Sewer Rental Rates be passed and adopted.

ROLL CALL: Welch, Hartmann, Hawkins, McKinney and Miller voting aye.

6. It was moved by McKinney and seconded by Welch that the Third Reading of a proposed Ordinance, an Ordinance amending the Code of Ordinances of the City of Webster City, Iowa, 2019, by Amending Chapter 48 Pertaining to Water System Rates be approved.

ROLL CALL: Hartmann, Hawkins, McKinney, Miller and Welch voting aye.

- a. It was moved by McKinney and seconded by Welch that Ordinance No. 2021-1847, an Ordinance amending the Code of Ordinances of the City of Webster City, Iowa, 2019, by Amending Chapter 48 Pertaining to Water System Rates be approved.

ROLL CALL: Hawkins, McKinney, Miller, Welch and Hartmann voting aye.

7. It was moved by Welch and seconded by McKinney that Request from Recreation and Public Grounds Director to approve estimate in the amount of \$15,146.14 from Mustang Disaster Clean Up, Ellsworth, IA for Mold Remediation at the Historic Train Depot and 1st Hamilton County Courthouse and move forward with the remediation, be approved.

ROLL CALL: McKinney, Miller, Welch, Hartmann and Hawkins voting aye.

City Council Meeting Minutes, July 19, 2021

8. It was moved by McKinney and seconded by Welch that the Planning and Zoning Commission Meeting Minutes from July 12, 2021 be accepted and placed on file.

ROLL CALL: Miller, Welch, Hartmann, Hawkins and McKinney voting aye.

9. It was moved by McKinney and seconded by Miller that Resolution No. 2021-154 setting August 2, 2021 at 6:05 p.m. in Council Chambers at City Hall, Webster City, Iowa for a Public Hearing on the proposed amending of the Code of Ordinances of the City of Webster City, Iowa, by amending Chapter 50 pertaining to Zoning as it relates to Uses Permitted in the M-1 (Light Industrial) District be passed and adopted.

ROLL CALL: Welch, Hartmann, Hawkins, McKinney and Miller voting aye.

REPORTS AND RECOMMENDATIONS OF OFFICERS, BOARDS AND COMMISSIONS

It was moved by Welch and seconded by Miller that the following items (1-3) be accepted and placed on file:

1. Police Department Report for June 2021;
2. Inspection Department Report for June 2021;
3. Hamilton County Solid Waste July Agenda Packet;

COUNCIL COMMITTEE REPORTS

None brought forth.

OTHER REPORTS AND RECOMMENDATIONS

None brought forth.

OTHER ITEMS SENT TO COUNCIL

1. Council received information from Police Chief Shiloh Mork in regard to Street Closures from 4-8 p.m. for National Night Out that will be held at West Twin Park on Tuesday, August 3rd, 2021.

It was moved by Miller and seconded by McKinney that Council adjourn.

ROLL CALL: Hawkins, McKinney, Miller, Welch and Hartmann voting aye.

The July 19, 2021 Regular City Council Meeting stood adjourned at 6:57 p.m.

John Hawkins, Mayor

Karyl K. Bonjour, City Clerk

RESOLUTION NO. 2021 -

BE IT RESOLVED BY THE CITY COUNCIL OF THE CITY OF WEBSTER CITY,
IOWA:

That the payroll for the 80-hour period ending July 17, 2021 and paid on
July 23, 2021 aggregating the sum of \$185,185.52 herewith presented,
be and the same is hereby approved.

Passed and adopted this 2nd day of August, 2021.

John Hawkins, Mayor

ATTEST:

Karyl K. Bonjour, City Clerk

| Employee Number | Name | Total Gross Amount | Total Gross Hours | 3-00 OT no pen Emp Amt | 4-00 OT pension Emp Amt | 5-00 DBL OT np Emp Amt | 6-00 DBL OT pen Emp Amt | 23-00 OTHER pen Emp Amt | 24-00 OTHER np Emp Amt | 85-00 NET PAY Emp Amt | 86-00 DIRECT DEP Emp Amt |
|--------------------------|------------------------|--------------------|-------------------|------------------------|-------------------------|------------------------|-------------------------|-------------------------|------------------------|-----------------------|--------------------------|
| 81719 | SCHULTZ, CAMDEN J. | 354.38 | 40.50 | .00 | .00 | .00 | .00 | .00 | .00 | .00 | 327.27 |
| 81733 | SEELEY, KAITLYNN R. | 561.00 | 66.00 | .00 | .00 | .00 | .00 | .00 | .00 | 494.26 | .00 |
| 81703 | SEISER, DAWSON K. | 365.75 | 38.50 | .00 | .00 | .00 | .00 | .00 | .00 | .00 | 329.77 |
| 81710 | SOSA-BAEZ, ABILENE | 383.88 | 40.75 | .00 | .00 | .00 | .00 | .00 | .00 | .00 | 345.51 |
| 81715 | STOAKES, KELLY L. | 39.38 | 4.50 | .00 | .00 | .00 | .00 | .00 | .00 | .00 | 36.37 |
| 81718 | THONGSOUK, TAHSAIYA W. | 402.50 | 46.00 | .00 | .00 | .00 | .00 | .00 | .00 | .00 | 362.70 |
| 81699 | WHITMORE, MAX F. | 300.00 | 32.00 | .00 | .00 | .00 | .00 | .00 | .00 | 272.05 | .00 |
| 81650 | WILLSON, JACOB B. | 161.13 | 17.50 | .00 | .00 | .00 | .00 | .00 | .00 | .00 | 148.80 |
| Total RECREATION: | | | | | | | | | | | |
| | | 42 | 17,276.62 | 1,445.00 | .00 | 265.20 | .00 | .00 | .00 | 4,190.64 | 10,083.27 |
| 51187 | BAHRENFUSS, BRANDON D. | 2,723.20 | 80.00 | .00 | .00 | .00 | .00 | .00 | .00 | .00 | 1,877.97 |
| 51178 | DOOLITTLE, DAN L | 880.00 | 40.00 | .00 | .00 | .00 | .00 | .00 | .00 | .00 | 692.79 |
| 51189 | MACRUNNEL, MATTHEW A. | 1,827.20 | 80.00 | .00 | .00 | .00 | .00 | .00 | .00 | .00 | 1,305.77 |
| 51200 | MCKIBBAN, JACOB D. | 1,857.39 | 81.00 | .00 | 34.19 | .00 | .00 | .00 | .00 | .00 | 1,320.28 |
| 31195 | PETERSON, RICK E. | 1,834.40 | 80.00 | .00 | .00 | .00 | .00 | .00 | .00 | .00 | 1,267.97 |
| 51190 | RATCLIFF, BRETT D. | 1,997.60 | 80.00 | .00 | .00 | .00 | .00 | .00 | .00 | .00 | 1,322.97 |
| 51195 | RODEN, JACOB J. | 1,823.20 | 80.00 | .00 | .00 | .00 | .00 | .00 | .00 | .00 | 1,220.51 |
| 51184 | WILLIAMS, ZACHARY W. | 2,187.20 | 80.00 | .00 | .00 | .00 | .00 | .00 | .00 | .00 | 1,466.09 |
| 51205 | YOUNGDALE, COLE C. | 1,920.00 | 80.00 | .00 | .00 | .00 | .00 | .00 | .00 | .00 | 1,348.84 |
| Total STREET DEPARTMENT: | | | | | | | | | | | |
| | | 9 | 17,050.19 | 681.00 | .00 | 34.19 | .00 | .00 | .00 | .00 | 11,823.19 |
| 30772 | DINGMAN, CHAD M. | 2,209.60 | 80.00 | .00 | .00 | .00 | .00 | .00 | .00 | .00 | 1,639.83 |
| 30977 | JACKSON, JEFFREY S. | 1,972.00 | 80.00 | .00 | .00 | .00 | .00 | .00 | .00 | .00 | 1,366.47 |
| 31179 | WEST, JOHN A. | 2,188.51 | 89.00 | .00 | .00 | .00 | .00 | .00 | .00 | .00 | 1,561.07 |
| Total WASTEWATER: | | | | | | | | | | | |
| | | 3 | 6,370.11 | 249.00 | .00 | .00 | .00 | .00 | .00 | .00 | 4,567.37 |
| 31189 | CHAMBERS, TODD A. | 2,704.44 | 89.00 | .00 | .00 | .00 | .00 | .00 | .00 | .00 | 1,768.43 |
| 31191 | DANIELSON, TIMOTHY E. | 3,671.72 | 88.00 | .00 | .00 | .00 | .00 | .00 | .00 | .00 | 2,473.00 |
| 31220 | FARWELL, GREGORY A. | 2,080.00 | 80.00 | .00 | .00 | .00 | .00 | .00 | .00 | .00 | 1,461.51 |
| 31215 | KNOWLES, NICHOLAS A. | 2,697.00 | 87.00 | .00 | .00 | .00 | .00 | .00 | .00 | .00 | 1,798.76 |
| 81729 | MURRAY, TUCKER MD | 288.00 | 24.00 | .00 | .00 | .00 | .00 | .00 | .00 | .00 | 256.29 |
| Total WATER PLANT: | | | | | | | | | | | |
| | | 5 | 11,441.16 | 368.00 | .00 | .00 | .00 | .00 | .00 | .00 | 7,757.99 |
| Grand Totals: | | | | | | | | | | | |
| | | 141 | 185,185.52 | 7,564.00 | 329.00 | 1,121.51 | .00 | 265.56 | 2,744.00 | .00 | 6,177.82 |

RESOLUTION NO. 2021 -

BE IT RESOLVED BY THE CITY COUNCIL OF THE CITY OF WEBSTER CITY,
IOWA:

That we, the City Council of the City of Webster City, Iowa, having examined bills aggregating the sum of \$223,925.28 presented herewith, hereby approve said bills, and the City Clerk is hereby authorized to issue warrants in payment of the same.

Passed and adopted this 2nd day of August, 2021.

John Hawkins, Mayor

ATTEST:

Karyl K. Bonjour, City Clerk

| Invoice | Seq | Type | Description | Invoice Date | Total Cost | Period | GL Account |
|----------------------------|-----|---------|-----------------------------|--------------|------------|--------|--------------------|
| CARD SERVICES (140) | | | | | | | |
| 0239 07/01/2 | 1 | Invoice | MESH VESTS | 07/01/2021 | 74.30 | 12/21 | 204-23-30-5310-312 |
| 0239 07/01/2 | 2 | Invoice | MESH VESTS | 07/01/2021 | 22.61 | 12/21 | 602-23-62-5662-312 |
| 0239 07/01/2 | 3 | Invoice | MESH VESTS | 07/01/2021 | 10.77 | 12/21 | 603-23-71-5662-312 |
| 0239 07/01/2 | 4 | Invoice | CONF REGISTRITON/BAHRENFUSS | 07/01/2021 | 572.01 | 12/21 | 204-23-30-5310-231 |
| 0239 07/01/2 | 5 | Invoice | CONF REGISTRITON/BAHRENFUSS | 07/01/2021 | 174.09 | 12/21 | 602-23-62-5662-231 |
| 0239 07/01/2 | 6 | Invoice | CONF REGISTRITON/BAHRENFUSS | 07/01/2021 | 82.90 | 12/21 | 603-23-71-5926-231 |
| 0239 07/01/2 | 7 | Invoice | CONF REGISTRITON/WILLIAMS | 07/01/2021 | 379.50 | 12/21 | 204-23-30-5310-231 |
| 0239 07/01/2 | 8 | Invoice | CONF REGISTRITON/WILLIAMS | 07/01/2021 | 115.50 | 12/21 | 602-23-62-5926-231 |
| 0239 07/01/2 | 9 | Invoice | CONF REGISTRITON/WILLIAMS | 07/01/2021 | 55.00 | 12/21 | 603-23-71-5926-231 |
| Total 0239 07/01/2021: | | | | | 1,486.68 | | |
| Total CARD SERVICES (140): | | | | | 1,486.68 | | |
| Total 07/22/2021: | | | | | 1,486.68 | | |

| Invoice | Seq | Type | Description | Invoice Date | Total Cost | Period | GL Account |
|---|-----|---------|---|--------------|------------|--------|--------------------|
| ACCU JET SEWER AND DRAIN CLEANING (5369) | | | | | | | |
| 5320 | 1 | Invoice | SANITARY SEWER SLIP LINE - BLUFF ST 6/2 | 07/07/2021 | 20,262.00 | 12/21 | 603-23-71-5673-229 |
| Total 5320: | | | | | 20,262.00 | | |
| Total ACCU JET SEWER AND DRAIN CLEANING (5369): | | | | | 20,262.00 | | |
| AFLAC, INC. (20) | | | | | | | |
| 519575 | 1 | Invoice | AFLAC PREMIUMS | 07/12/2021 | 2,056.04 | 02/22 | 902-11215 |
| Total 519575: | | | | | 2,056.04 | | |
| Total AFLAC, INC. (20): | | | | | 2,056.04 | | |
| AGSOURCE (4458) | | | | | | | |
| PS-INV1473 | 1 | Invoice | WATER TEST / BOIL ORDER - WATERMAIN B | 06/30/2021 | 13.50 | 12/21 | 602-23-62-5673-299 |
| Total PS-INV147374: | | | | | 13.50 | | |
| PS-INV1504 | 1 | Invoice | OD POOL WATER TESTING | 07/21/2021 | 39.00 | 01/22 | 100-22-42-5242-299 |
| Total PS-INV150415: | | | | | 39.00 | | |
| Total AGSOURCE (4458): | | | | | 52.50 | | |
| AMERICAN PLANNING ASSOCIATION (6662) | | | | | | | |
| 001827-2174 | 1 | Invoice | APA MEMBERSHIP/WETZLER | 07/13/2021 | 313.00 | 02/22 | 100-24-18-5470-215 |
| Total 001827-2174: | | | | | 313.00 | | |
| Total AMERICAN PLANNING ASSOCIATION (6662): | | | | | 313.00 | | |
| AMERICAN PUBLIC WORKS ASSOC. (43) | | | | | | | |
| 890219 | 1 | Invoice | PWX - ST.LOUIS REGISTRATION - BRETT R | 07/21/2021 | 448.50 | 02/22 | 204-23-30-5310-231 |
| 890219 | 2 | Invoice | PWX - ST.LOUIS REGISTRATION - BRETT R | 07/21/2021 | 136.50 | 02/22 | 602-23-62-5926-231 |
| 890219 | 3 | Invoice | PWX - ST.LOUIS REGISTRATION - BRETT R | 07/21/2021 | 65.00 | 02/22 | 603-23-71-5926-231 |
| Total 890219: | | | | | 650.00 | | |
| Total AMERICAN PUBLIC WORKS ASSOC. (43): | | | | | 650.00 | | |
| ARNOLD MOTOR SUPPLY (68) | | | | | | | |
| 26NV053732 | 1 | Invoice | BLK TIE WRAP | 07/16/2021 | 5.34 | 01/22 | 601-23-52-5588-318 |
| Total 26NV053732: | | | | | 5.34 | | |
| 26NV053871 | 1 | Invoice | HD NITRITE-FREE - BORING UNIT | 07/20/2021 | 25.01 | 01/22 | 601-23-52-5935-315 |
| Total 26NV053871: | | | | | 25.01 | | |
| Total ARNOLD MOTOR SUPPLY (68): | | | | | 30.35 | | |
| ASTRA SECURITY (6495) | | | | | | | |
| 34357 | 1 | Invoice | FOBS & KEY CARDS | 07/13/2021 | 33.60 | 02/22 | 100-24-36-5480-226 |
| 34357 | 2 | Invoice | FOBS & KEY CARDS | 07/13/2021 | 24.00 | 02/22 | 601-23-36-5480-226 |
| 34357 | 3 | Invoice | FOBS & KEY CARDS | 07/13/2021 | 19.20 | 02/22 | 602-23-36-5480-226 |
| 34357 | 4 | Invoice | FOBS & KEY CARDS | 07/13/2021 | 19.20 | 02/22 | 603-23-36-5480-226 |

| Invoice | Seq | Type | Description | Invoice Date | Total Cost | Period | GL Account |
|----------------------------------|-----|---------|------------------------------|--------------|------------|--------|--------------------|
| Total 34357: | | | | | 96.00 | | |
| Total ASTRA SECURITY (6495): | | | | | 96.00 | | |
| AVAILA BANK (6318) | | | | | | | |
| 072621 | 1 | Invoice | FULLER HALL PRINCIPAL PYMT | 07/26/2021 | 5,141.35 | 02/22 | 300-22-98-5295-910 |
| 072621 | 2 | Invoice | FULLER HALL INTEREST PYMT | 07/26/2021 | 4,012.95 | 02/22 | 300-22-98-5295-911 |
| Total 072621: | | | | | 9,154.30 | | |
| Total AVAILA BANK (6318): | | | | | 9,154.30 | | |
| BAYNE, KAITLIN (7343) | | | | | | | |
| 917350018 | 1 | Invoice | CUSTOMER DEPOSIT REFUND | 07/26/2021 | 14.39 | 02/22 | 601-21011 |
| Total 917350018: | | | | | 14.39 | | |
| Total BAYNE, KAITLIN (7343): | | | | | 14.39 | | |
| BLACK HILLS ENERGY (3466) | | | | | | | |
| 0976116930 | 1 | Invoice | GAS UTILITY/LINE DEPT | 07/09/2021 | 11.58 | 02/22 | 601-23-52-5586-234 |
| 0976116930 | 2 | Invoice | GAS UTILITY/LINE DEPT | 07/09/2021 | 11.59 | 02/22 | 601-23-52-5588-234 |
| 0976116930 | 3 | Invoice | GAS UTILITY/LINE DEPT | 07/09/2021 | 11.59 | 02/22 | 601-23-51-5566-234 |
| Total 0976116930 07/09/21: | | | | | 34.76 | | |
| 2074831097 | 1 | Invoice | GAS UTILITY/CEMETERY | 07/21/2021 | 35.82 | 02/22 | 100-23-42-5371-234 |
| Total 2074831097 07/21/21: | | | | | 35.82 | | |
| 4752063290 | 1 | Invoice | GAS UTILITY/DEPOT | 07/15/2021 | 35.54 | 02/22 | 100-22-42-5221-234 |
| Total 4752063290 08/15/21: | | | | | 35.54 | | |
| 5470636360 | 1 | Invoice | GAS UTILITY/FULLER HALL | 07/16/2021 | 193.86 | 02/22 | 100-22-42-5233-234 |
| Total 5470636360 07/16/21: | | | | | 193.86 | | |
| 5542531803 | 1 | Invoice | GAS UTILITY/FIRE STATION | 07/15/2021 | 35.50 | 02/22 | 100-21-22-5140-234 |
| Total 5542531803 07/15/21: | | | | | 35.50 | | |
| 5978424719 | 1 | Invoice | GAS UTILITY/WATER PLANT SHED | 07/09/2021 | 42.20 | 02/22 | 602-23-61-5642-234 |
| Total 5978424719 07/09/21: | | | | | 42.20 | | |
| 6506969580 | 1 | Invoice | GAS UTILITY/WATER PLANT | 07/09/2021 | 34.76 | 02/22 | 602-23-61-5642-234 |
| Total 6506969580 07/09/21: | | | | | 34.76 | | |
| 8081102404 | 1 | Invoice | GAS UTILITY/SENIOR CENTER | 07/15/2021 | 84.17 | 02/22 | 100-21-22-5140-234 |
| Total 8081102404 07/15/21: | | | | | 84.17 | | |
| Total BLACK HILLS ENERGY (3466): | | | | | 496.61 | | |

| Invoice | Seq | Type | Description | Invoice Date | Total Cost | Period | GL Account |
|-------------------------------------|-----|---------|---------------------------------------|--------------|------------|--------|--------------------|
| BOLTON & MENK INC. (106) | | | | | | | |
| 0272001 | 1 | Invoice | CONSULTING SVC FOR WASTEWATER ISSU | 06/30/2021 | 2,152.50 | 12/21 | 603-23-70-5923-212 |
| Total 0272001: | | | | | 2,152.50 | | |
| 0272002 | 1 | Invoice | ENG - WASTEWATER DESIGN-FACILITY IMP | 06/30/2021 | 2,145.00 | 12/21 | 603-23-70-5652-860 |
| Total 0272002: | | | | | 2,145.00 | | |
| Total BOLTON & MENK INC. (106): | | | | | 4,297.50 | | |
| BOMGAARS (5165) | | | | | | | |
| 62743988 | 1 | Invoice | PAINT/RAGBRAI | 07/06/2021 | 25.75 | 02/22 | 430-23-42-5222-318 |
| Total 62743988: | | | | | 25.75 | | |
| 62744696 | 1 | Invoice | HOSE CLAMP, INSERT ELBOW & ADAPTER | 07/08/2021 | 5.96 | 01/22 | 602-23-61-5642-318 |
| Total 62744696: | | | | | 5.96 | | |
| 62746433 | 1 | Invoice | PRAMITOL WEED KILLER | 07/12/2021 | 59.99 | 01/22 | 602-23-61-5651-310 |
| 62746433 | 2 | Invoice | CAULK & PUTTY KNIVES | 07/12/2021 | 10.97 | 01/22 | 602-23-61-5642-318 |
| Total 62746433: | | | | | 70.96 | | |
| 62746756 | 1 | Invoice | PUSHBROOM-SCRUB BRUSH-ANGLE IRON- | 07/13/2021 | 103.20 | 01/22 | 603-23-70-5642-318 |
| Total 62746756: | | | | | 103.20 | | |
| 62746874 | 1 | Invoice | 2 WHEELS - RUBBER PLUG - RAPTOR BLAD | 07/13/2021 | 78.96 | 01/22 | 603-23-70-5642-318 |
| Total 62746874: | | | | | 78.96 | | |
| 62747053 | 1 | Invoice | TAPE MEASURE | 07/14/2021 | 29.99 | 01/22 | 601-23-52-5588-311 |
| 62747053 | 2 | Invoice | SUPPLIES | 07/14/2021 | 87.58 | 01/22 | 601-23-52-5588-318 |
| Total 62747053: | | | | | 117.57 | | |
| 62747464 | 1 | Invoice | SPRAY PAINT & SANDING SPONGE (CITY HA | 07/15/2021 | 3.34 | 01/22 | 100-24-36-5480-318 |
| 62747464 | 2 | Invoice | SPRAY PAINT & SANDING SPONGE | 07/15/2021 | 2.40 | 01/22 | 601-23-36-5480-318 |
| 62747464 | 3 | Invoice | SPRAY PAINT & SANDING SPONGE | 07/15/2021 | 1.92 | 01/22 | 602-23-36-5480-318 |
| 62747464 | 4 | Invoice | SPRAY PAINT & SANDING SPONGE | 07/15/2021 | 1.92 | 01/22 | 603-23-36-5480-318 |
| Total 62747464: | | | | | 9.58 | | |
| 62747478 | 1 | Invoice | WEED SPRAYER/PEAT MOSS | 07/15/2021 | 102.91 | 02/22 | 100-21-22-5140-318 |
| Total 62747478: | | | | | 102.91 | | |
| 62747822 | 1 | Invoice | FASTENERS & DISPENSER BLADE | 07/16/2021 | 35.98 | 01/22 | 601-23-52-5588-318 |
| Total 62747822: | | | | | 35.98 | | |
| 62749143 | 1 | Invoice | DIRECT DRIVE FAN - SHOP | 07/19/2021 | 149.99 | 01/22 | 204-23-30-5310-311 |
| Total 62749143: | | | | | 149.99 | | |
| 62749526 | 1 | Invoice | MALE ADAPTER | 07/20/2021 | 5.79 | 01/22 | 602-23-61-5642-318 |

| Invoice | Seq | Type | Description | Invoice Date | Total Cost | Period | GL Account |
|---|-----|---------|----------------------------------|--------------|------------|--------|--------------------|
| Total 62749526: | | | | | 5.79 | | |
| 62750096 | 1 | Invoice | 2 FEMALE ADAPTERS (W.TWIN) | 07/21/2021 | 1.18 | 01/22 | 100-22-42-5210-880 |
| Total 62750096: | | | | | 1.18 | | |
| 62750341 | 1 | Invoice | ELECTRICAL TAPE & 2 COMP UNIONS | 07/22/2021 | 13.36 | 01/22 | 602-23-61-5642-318 |
| Total 62750341: | | | | | 13.36 | | |
| 62751998 | 1 | Invoice | J-BOLT & BULK BOLTS | 07/26/2021 | 3.64 | 01/22 | 602-23-61-5642-318 |
| Total 62751998: | | | | | 3.64 | | |
| Total BOMGAARS (5165): | | | | | 724.83 | | |
| BROWN SUPPLY COMPANY, INC. (122) | | | | | | | |
| 112254 | 1 | Invoice | MANHOLE FRAMES & LIDS | 07/15/2021 | 2,359.50 | 01/22 | 204-23-30-5330-318 |
| 112254 | 2 | Invoice | MANHOLE FRAMES & LIDS | 07/15/2021 | 1,501.50 | 01/22 | 603-23-71-5662-318 |
| Total 112254: | | | | | 3,861.00 | | |
| Total BROWN SUPPLY COMPANY, INC. (122): | | | | | 3,861.00 | | |
| CALDERON, FREEMAN (7337) | | | | | | | |
| 070721 | 1 | Invoice | ELECTRIC REFUND | 07/07/2021 | 195.11 | 02/22 | 601-23-80-5903-980 |
| Total 070721: | | | | | 195.11 | | |
| Total CALDERON, FREEMAN (7337): | | | | | 195.11 | | |
| CAPITAL SANITARY SUPPLY (6096) | | | | | | | |
| C308143D | 1 | Invoice | NITRILE GLOVES | 07/07/2021 | 178.70 | 02/22 | 100-22-42-5233-318 |
| Total C308143D: | | | | | 178.70 | | |
| C331369 | 1 | Invoice | BOTTLE/CLEANER | 07/21/2021 | 51.32 | 02/22 | 100-24-36-5480-318 |
| C331369 | 2 | Invoice | BOTTLE/CLEANER | 07/21/2021 | 36.66 | 02/22 | 601-23-36-5480-318 |
| C331369 | 3 | Invoice | BOTTLE/CLEANER | 07/21/2021 | 29.32 | 02/22 | 602-23-36-5480-318 |
| C331369 | 4 | Invoice | BOTTLE/CLEANER | 07/21/2021 | 29.32 | 02/22 | 603-23-36-5480-318 |
| Total C331369: | | | | | 146.62 | | |
| Total CAPITAL SANITARY SUPPLY (6096): | | | | | 325.32 | | |
| CARRANZA, CYNTAIA MAYELA (7340) | | | | | | | |
| 1434090519 | 1 | Invoice | CUSTOMER DEPOSIT REFUND | 07/21/2021 | 77.58 | 02/22 | 601-21011 |
| Total 1434090519: | | | | | 77.58 | | |
| Total CARRANZA, CYNTAIA MAYELA (7340): | | | | | 77.58 | | |
| CARRICO AQUATIC RESOURCES (6820) | | | | | | | |
| 20213810 | 1 | Invoice | CHEMICAL FOR OD POOL 2021 SEASON | 07/07/2021 | 5,060.20 | 01/22 | 100-22-42-5242-318 |
| Total 20213810: | | | | | 5,060.20 | | |

| Invoice | Seq | Type | Description | Invoice Date | Total Cost | Period | GL Account |
|---|-----|---------|-----------------------------|--------------|------------|--------|--------------------|
| Total CARRICO AQUATIC RESOURCES (6820): | | | | | 5,060.20 | | |
| CARTER, CHRISTIE (7253) | | | | | | | |
| 040721 | 1 | Invoice | ENERGY EFFICIENCY REABTE | 04/07/2021 | 100.00 | 12/21 | 601-23-36-5930-979 |
| 040721 | 2 | Invoice | CORN BELT INSULATION REBATE | 04/07/2021 | 127.36 | 12/21 | 601-23-53-5930-979 |
| Total 040721: | | | | | 227.36 | | |
| Total CARTER, CHRISTIE (7253): | | | | | 227.36 | | |
| CENTRAL IOWA BLDG SUPPLY (1298) | | | | | | | |
| 10090922 | 1 | Invoice | REBAR | 07/16/2021 | 97.84 | 02/22 | 204-23-30-5330-318 |
| 10090922 | 2 | Invoice | REBAR | 07/16/2021 | 29.78 | 02/22 | 602-23-62-5662-318 |
| 10090922 | 3 | Invoice | REBAR | 07/16/2021 | 14.18 | 02/22 | 603-23-71-5662-318 |
| Total 10090922: | | | | | 141.80 | | |
| Total CENTRAL IOWA BLDG SUPPLY (1298): | | | | | 141.80 | | |
| CENTRAL IOWA DISTRIBUTING, INC (153) | | | | | | | |
| 213639 | 1 | Invoice | GLOVES & TOWELS | 07/08/2021 | 213.00 | 01/22 | 603-23-70-5642-318 |
| Total 213639: | | | | | 213.00 | | |
| 213921 | 1 | Invoice | PARK BATHROOM SUPPLIES | 07/15/2021 | 279.00 | 02/22 | 100-22-42-5210-318 |
| Total 213921: | | | | | 279.00 | | |
| Total CENTRAL IOWA DISTRIBUTING, INC (153): | | | | | 492.00 | | |
| CENTRAL IOWA FARM STORE (7129) | | | | | | | |
| 99728M | 1 | Invoice | V-BELT | 07/20/2021 | 52.70 | 01/22 | 100-23-42-5371-314 |
| Total 99728M: | | | | | 52.70 | | |
| Total CENTRAL IOWA FARM STORE (7129): | | | | | 52.70 | | |
| CENTURY LINK (4614) | | | | | | | |
| 234651799 | 1 | Invoice | TELEPHONE SERVICE | 07/12/2021 | 9.71 | 12/21 | 100-24-12-5430-230 |
| 234651799 | 2 | Invoice | TELEPHONE SERVICE | 07/12/2021 | 19.45 | 12/21 | 602-23-81-5921-230 |
| 234651799 | 3 | Invoice | TELEPHONE SERVICE | 07/12/2021 | 32.42 | 12/21 | 601-23-81-5921-230 |
| 234651799 | 4 | Invoice | TELEPHONE SERVICE | 07/12/2021 | 3.24 | 12/21 | 603-23-81-5921-230 |
| 234651799 | 5 | Invoice | TELEPHONE SERVICE | 07/12/2021 | 5.83 | 12/21 | 100-24-14-5435-230 |
| 234651799 | 6 | Invoice | TELEPHONE SERVICE | 07/12/2021 | 12.97 | 12/21 | 602-23-80-5921-230 |
| 234651799 | 7 | Invoice | TELEPHONE SERVICE | 07/12/2021 | 3.90 | 12/21 | 603-23-80-5921-230 |
| 234651799 | 8 | Invoice | TELEPHONE SERVICE | 07/12/2021 | 42.14 | 12/21 | 601-23-80-5903-230 |
| 234651799 | 9 | Invoice | TELEPHONE SERVICE | 07/12/2021 | 35.66 | 12/21 | 100-24-30-5380-230 |
| 234651799 | 10 | Invoice | TELEPHONE SERVICE | 07/12/2021 | 12.97 | 12/21 | 100-24-18-5470-230 |
| 234651799 | 11 | Invoice | TELEPHONE SERVICE | 07/12/2021 | 16.21 | 12/21 | 100-21-18-5190-230 |
| 234651799 | 12 | Invoice | TELEPHONE SERVICE | 07/12/2021 | 32.19 | 12/21 | 204-23-30-5320-230 |
| 234651799 | 13 | Invoice | TELEPHONE SERVICE | 07/12/2021 | 75.56 | 12/21 | 100-21-22-5140-230 |
| 234651799 | 14 | Invoice | TELEPHONE SERVICE | 07/12/2021 | 75.56 | 12/21 | 100-23-42-5371-230 |
| 234651799 | 15 | Invoice | TELEPHONE SERVICE | 07/12/2021 | 75.56 | 12/21 | 601-23-52-5588-230 |
| 234651799 | 16 | Invoice | TELEPHONE SERVICE | 07/12/2021 | 75.56 | 12/21 | 100-22-42-5233-230 |
| 234651799 | 17 | Invoice | TELEPHONE SERVICE | 07/12/2021 | 75.56 | 12/21 | 204-23-30-5310-230 |
| 234651799 | 18 | Invoice | TELEPHONE SERVICE | 07/12/2021 | 75.56 | 12/21 | 603-23-70-5642-230 |
| 234651799 | 19 | Invoice | TELEPHONE SERVICE | 07/12/2021 | 75.56 | 12/21 | 602-23-61-5642-230 |

| Invoice | Seq | Type | Description | Invoice Date | Total Cost | Period | GL Account |
|-----------------------------------|-----|---------|------------------------------------|--------------|------------|--------|--------------------|
| Total 234651799: | | | | | 755.61 | | |
| 832-2525 07/ | 1 | Invoice | PHONE SERVICE-SENIOR CENTER | 07/22/2021 | 145.02 | 02/22 | 100-22-42-5280-230 |
| Total 832-2525 07/22/21: | | | | | 145.02 | | |
| 832-9166 07/ | 1 | Invoice | PHONE SERVICE - POLICE DEPT | 07/22/2021 | 313.78 | 02/22 | 100-21-21-5110-230 |
| Total 832-9166 07/22/21: | | | | | 313.78 | | |
| 832-9190 07/ | 1 | Invoice | PHONE SERVICE-OD POOL | 07/22/2021 | 61.71 | 02/22 | 100-22-42-5242-230 |
| Total 832-9190 07/22/21: | | | | | 61.71 | | |
| Total CENTURY LINK (4614): | | | | | 1,276.12 | | |
| CHIZEK LAW OFFICE (5715) | | | | | | | |
| 072621 | 1 | Invoice | CITY ATTORNEY FEES/AUGUST 2021 | 07/26/2021 | 1,166.67 | 02/22 | 100-24-13-5460-212 |
| 072621 | 2 | Invoice | CITY ATTORNEY FEES/AUGUST 2021 | 07/26/2021 | 3,208.33 | 02/22 | 601-24-13-5460-212 |
| 072621 | 3 | Invoice | CITY ATTORNEY FEES/AUGUST 2021 | 07/26/2021 | 729.17 | 02/22 | 602-24-13-5460-212 |
| 072621 | 4 | Invoice | CITY ATTORNEY FEES/AUGUST 2021 | 07/26/2021 | 729.16 | 02/22 | 603-24-13-5460-212 |
| Total 072621: | | | | | 5,833.33 | | |
| 073121 | 1 | Invoice | COSTS ADVANCED/MISC CHARGES | 07/31/2021 | 123.76 | 02/22 | 100-21-18-5190-214 |
| 073121 | 2 | Invoice | COSTS ADVANCED/MISC CHARGES | 07/31/2021 | 535.00 | 12/21 | 100-21-18-5190-214 |
| 073121 | 3 | Invoice | COSTS ADVANCED/MISC CHARGES | 07/31/2021 | 641.00 | 12/21 | 100-21-18-5190-214 |
| Total 073121: | | | | | 1,299.76 | | |
| Total CHIZEK LAW OFFICE (5715): | | | | | 7,133.09 | | |
| Ci CONCRETE INC. (6909) | | | | | | | |
| 195570 | 1 | Invoice | CONCRETE - WATERMAIN MAINT CEDAR & | 07/13/2021 | 475.41 | 01/22 | 602-23-62-5662-318 |
| Total 195570: | | | | | 475.41 | | |
| 195614 | 1 | Invoice | CONCRETE - WATERMAIN MAINT CEDAR & | 07/14/2021 | 1,201.23 | 01/22 | 602-23-62-5662-318 |
| Total 195614: | | | | | 1,201.23 | | |
| 195688 | 1 | Invoice | CONCRETE - WATERMAIN MAINT CEDAR & | 07/16/2021 | 734.09 | 01/22 | 602-23-62-5662-318 |
| Total 195688: | | | | | 734.09 | | |
| 195755 | 1 | Invoice | CONCRETE - WATERMAIN MAINT CEDAR & | 07/19/2021 | 475.41 | 01/22 | 602-23-62-5662-318 |
| Total 195755: | | | | | 475.41 | | |
| Total Ci CONCRETE INC. (6909): | | | | | 2,886.14 | | |
| CITY OF WEBSTER CITY (176) | | | | | | | |
| 072621 | 1 | Invoice | CITY UTILITIES | 07/26/2021 | 583.36 | 02/22 | 100-24-36-5480-233 |
| 072621 | 2 | Invoice | CITY UTILITIES | 07/26/2021 | 416.69 | 02/22 | 601-23-36-5480-233 |
| 072621 | 3 | Invoice | CITY UTILITIES | 07/26/2021 | 333.35 | 02/22 | 602-23-36-5480-233 |
| 072621 | 4 | Invoice | CITY UTILITIES | 07/26/2021 | 333.34 | 02/22 | 603-23-36-5480-233 |
| 072621 | 5 | Invoice | CITY UTILITIES | 07/26/2021 | 982.45 | 02/22 | 100-21-22-5140-233 |

| Invoice | Seq | Type | Description | Invoice Date | Total Cost | Period | GL Account |
|---|-----|---------|---------------------------------------|--------------|------------|--------|--------------------|
| 072621 | 6 | Invoice | CITY UTILITIES | 07/26/2021 | 494.61 | 02/22 | 204-23-30-5310-233 |
| 072621 | 7 | Invoice | CITY UTILITIES | 07/26/2021 | 614.30 | 02/22 | 100-21-30-5120-233 |
| 072621 | 8 | Invoice | CITY UTILITIES | 07/26/2021 | 178.96 | 02/22 | 602-23-62-5662-233 |
| 072621 | 9 | Invoice | CITY UTILITIES | 07/26/2021 | 508.01 | 02/22 | 603-23-71-5662-233 |
| 072621 | 10 | Invoice | CITY UTILITIES | 07/26/2021 | 16,156.91 | 02/22 | 603-23-70-5642-233 |
| 072621 | 11 | Invoice | CITY UTILITIES | 07/26/2021 | 9,941.55 | 02/22 | 100-21-30-5160-233 |
| 072621 | 12 | Invoice | CITY UTILITIES | 07/26/2021 | 367.88 | 02/22 | 100-22-42-5221-233 |
| 072621 | 13 | Invoice | CITY UTILITIES | 07/26/2021 | 302.62 | 02/22 | 100-22-42-5210-233 |
| 072621 | 14 | Invoice | CITY UTILITIES | 07/26/2021 | 26.32 | 02/22 | 100-22-42-5210-233 |
| 072621 | 15 | Invoice | CITY UTILITIES | 07/26/2021 | 239.00 | 02/22 | 100-22-42-5222-233 |
| 072621 | 16 | Invoice | CITY UTILITIES | 07/26/2021 | 994.66 | 02/22 | 100-22-42-5233-233 |
| 072621 | 17 | Invoice | CITY UTILITIES | 07/26/2021 | 380.67 | 02/22 | 100-23-42-5371-233 |
| 072621 | 18 | Invoice | CITY UTILITIES | 07/26/2021 | 9,011.82 | 02/22 | 602-23-60-5601-233 |
| 072621 | 19 | Invoice | CITY UTILITIES | 07/26/2021 | 125.68 | 02/22 | 601-23-51-5566-233 |
| 072621 | 20 | Invoice | CITY UTILITIES | 07/26/2021 | 129.48 | 02/22 | 601-23-52-5588-233 |
| 072621 | 21 | Invoice | CITY UTILITIES | 07/26/2021 | 125.67 | 02/22 | 601-23-52-5586-233 |
| 072621 | 22 | Invoice | CITY UTILITIES | 07/26/2021 | 7,526.96 | 02/22 | 100-22-42-5242-233 |
| 072621 | 23 | Invoice | CITY UTILITIES | 07/26/2021 | 2,888.34 | 02/22 | 602-23-61-5642-233 |
| 072621 | 24 | Invoice | CITY UTILITIES | 07/26/2021 | 127.98 | 02/22 | 100-23-43-5361-233 |
| 072621 | 25 | Invoice | CITY UTILITIES | 07/26/2021 | 791.55 | 02/22 | 100-22-42-5280-233 |
| 072621 | 26 | Invoice | CITY UTILITIES | 07/26/2021 | 361.74 | 02/22 | 100-21-22-5140-233 |
| 072621 | 27 | Invoice | CITY UTILITIES | 07/26/2021 | 418.09 | 02/22 | 204-23-30-5310-233 |
| Total 072621: | | | | | 54,361.99 | | |
| 072621 SHE | 1 | Invoice | CITY UTILITIES/WEST TWIN PARK SHELTER | 07/26/2021 | 85.57 | 02/22 | 100-22-42-5222-233 |
| Total 072621 SHELTER: | | | | | 85.57 | | |
| 072621 WEL | 1 | Invoice | CITY UTILITIES - WELL #8 | 07/26/2021 | 790.79 | 02/22 | 602-23-60-5601-233 |
| Total 072621 WELL #8: | | | | | 790.79 | | |
| Total CITY OF WEBSTER CITY (176): | | | | | 55,238.35 | | |
| CIVIC SYSTEMS, LLC (178) | | | | | | | |
| CVC20989 | 1 | Invoice | SEMI-ANNUAL SOFTWARE SUPPORT | 06/24/2021 | 1,225.35 | 02/22 | 100-24-14-5435-212 |
| CVC20989 | 2 | Invoice | SEMI-ANNUAL SOFTWARE SUPPORT | 06/24/2021 | 8,849.75 | 02/22 | 601-23-80-5923-212 |
| CVC20989 | 3 | Invoice | SEMI-ANNUAL SOFTWARE SUPPORT | 06/24/2021 | 2,723.00 | 02/22 | 602-23-80-5923-212 |
| CVC20989 | 4 | Invoice | SEMI-ANNUAL SOFTWARE SUPPORT | 06/24/2021 | 816.90 | 02/22 | 603-23-80-5923-212 |
| Total CVC20989: | | | | | 13,615.00 | | |
| Total CIVIC SYSTEMS, LLC (178): | | | | | 13,615.00 | | |
| CORN BELT POWER COOP, INC. (197) | | | | | | | |
| 15116 | 1 | Invoice | PROGRAM & TEST RELAYS | 07/14/2021 | 1,163.88 | 01/22 | 601-23-51-5566-299 |
| Total 15116: | | | | | 1,163.88 | | |
| 15120 | 1 | Invoice | TAPE READINGS & REPORTS | 07/15/2021 | 40.00 | 12/21 | 601-23-51-5566-299 |
| Total 15120: | | | | | 40.00 | | |
| Total CORN BELT POWER COOP, INC. (197): | | | | | 1,203.88 | | |
| COUNSEL OFFICE & DOCUMENT (3995) | | | | | | | |
| 34AR558528 | 1 | Invoice | LEASE AGREEMENT & COPY CHARGE-STRE | 07/08/2021 | 67.12 | 01/22 | 204-23-30-5310-225 |

| Invoice | Seq | Type | Description | Invoice Date | Total Cost | Period | GL Account |
|--|-----|---------|---------------------------------------|--------------|------------|--------|--------------------|
| Total 34AR558528: | | | | | 67.12 | | |
| 34AR560215 | 1 | Invoice | PRINTER CONTRACT - WATER PLANT | 07/19/2021 | 30.67 | 01/22 | 602-23-61-5931-225 |
| Total 34AR560215: | | | | | 30.67 | | |
| 34AR560216 | 1 | Invoice | PRINTER CONTRACT - LINE DEPT | 07/19/2021 | 28.51 | 01/22 | 601-23-52-5931-225 |
| Total 34AR560216: | | | | | 28.51 | | |
| 34AR560217 | 1 | Invoice | PRINTER CONTRACT - WASTEWATER | 07/19/2021 | 20.49 | 01/22 | 603-23-70-5931-225 |
| Total 34AR560217: | | | | | 20.49 | | |
| 34AR560218 | 1 | Invoice | RICOH5300DN | 07/19/2021 | 8.50 | 02/22 | 100-24-14-5435-225 |
| 34AR560218 | 2 | Invoice | RICOH5300DN | 07/19/2021 | 61.40 | 02/22 | 601-23-80-5931-225 |
| 34AR560218 | 3 | Invoice | RICOH5300DN | 07/19/2021 | 18.89 | 02/22 | 602-23-80-5931-225 |
| 34AR560218 | 4 | Invoice | RICOH5300DN | 07/19/2021 | 5.67 | 02/22 | 603-23-80-5931-225 |
| Total 34AR560218: | | | | | 94.46 | | |
| Total COUNSEL OFFICE & DOCUMENT (3995): | | | | | 241.25 | | |
| CRESCENT ELECTRIC SUPPLY (203) | | | | | | | |
| S509310903. | 1 | Invoice | 50A BREAKER & BOX w/ OUTLET (RAGBRAI) | 07/12/2021 | 69.70 | 01/22 | 601-23-52-5588-318 |
| Total S509310903.001: | | | | | 69.70 | | |
| Total CRESCENT ELECTRIC SUPPLY (203): | | | | | 69.70 | | |
| CULLIGAN FORT DODGE (207) | | | | | | | |
| 072021 | 1 | Invoice | AIRPORT-SOFT WATER SERVICE | 07/20/2021 | 153.84 | 02/22 | 205-23-45-5372-299 |
| Total 072021: | | | | | 153.84 | | |
| Total CULLIGAN FORT DODGE (207): | | | | | 153.84 | | |
| DAILY FREEMAN JOURNAL, INC. (211) | | | | | | | |
| 000089 | 1 | Invoice | ADVERTISE JOB - PUBLIC GROUNDS TECH | 06/30/2021 | 483.75 | 12/21 | 100-22-42-5210-210 |
| Total 000089: | | | | | 483.75 | | |
| 000093 | 1 | Invoice | RECYCLING ADV | 06/30/2021 | 151.04 | 12/21 | 100-23-30-5340-235 |
| 000093 | 2 | Invoice | MY HOMETOWN/JUNE 2021 | 06/30/2021 | 272.25 | 12/21 | 601-23-81-5921-233 |
| 000093 | 3 | Invoice | MY HOMETOWN/JUNE 2021 | 06/30/2021 | 99.00 | 12/21 | 100-24-12-5430-233 |
| 000093 | 4 | Invoice | MY HOMETOWN/JUNE 2021 | 06/30/2021 | 61.87 | 12/21 | 602-23-81-5921-233 |
| 000093 | 5 | Invoice | MY HOMETOWN/JUNE 2021 | 06/30/2021 | 61.88 | 12/21 | 603-23-81-5921-233 |
| Total 000093: | | | | | 646.04 | | |
| 7218 | 1 | Invoice | ORD 2021-1845/STOP REQUIREMENTS | 07/23/2021 | 21.62 | 02/22 | 100-24-14-5435-210 |
| Total 7218: | | | | | 21.62 | | |
| 7223 | 1 | Invoice | CM 07/06/2021 | 07/20/2021 | 361.20 | 02/22 | 100-24-14-5435-210 |

| Invoice | Seq | Type | Description | Invoice Date | Total Cost | Period | GL Account |
|--|-----|---------|-------------------------------------|--------------|------------|--------|--------------------|
| Total 7223: | | | | | 361.20 | | |
| 7243 | 1 | Invoice | ORD 2021-1846/SEWER RATES | 07/23/2021 | 55.41 | 02/22 | 100-24-14-5435-210 |
| Total 7243: | | | | | 55.41 | | |
| 7244 | 1 | Invoice | ORD 2021-1847/WATER SYSTEM RATES | 07/23/2021 | 48.73 | 02/22 | 100-24-14-5435-210 |
| Total 7244: | | | | | 48.73 | | |
| Total DAILY FREEMAN JOURNAL, INC. (211): | | | | | 1,616.75 | | |
| DGR ENGINEERING (5967) | | | | | | | |
| 00247736 | 1 | Invoice | MISC ELECTRICAL SVCS | 07/09/2021 | 33.04 | 12/21 | 601-23-81-5923-212 |
| 00247736 | 2 | Invoice | MISC ELECTRICAL SVCS | 07/09/2021 | 74.34 | 12/21 | 601-23-80-5905-212 |
| 00247736 | 3 | Invoice | MISC ELECTRICAL SVCS | 07/09/2021 | 247.80 | 12/21 | 601-23-52-5923-212 |
| 00247736 | 4 | Invoice | MISC ELECTRICAL SVCS | 07/09/2021 | 37.17 | 12/21 | 601-23-51-5566-212 |
| 00247736 | 5 | Invoice | MISC ELECTRICAL SVCS | 07/09/2021 | 20.65 | 12/21 | 601-23-36-5923-212 |
| Total 00247736: | | | | | 413.00 | | |
| Total DGR ENGINEERING (5967): | | | | | 413.00 | | |
| DIDIO, PEGGY (7341) | | | | | | | |
| 1151000012 | 1 | Invoice | CUSTOMER DEPOSIT REFUND | 07/14/2021 | 5.22 | 02/22 | 601-21011 |
| Total 1151000012: | | | | | 5.22 | | |
| Total DIDIO, PEGGY (7341): | | | | | 5.22 | | |
| DOHMS, MARK (4064) | | | | | | | |
| 072621 | 1 | Invoice | REIMB/RAGBRAI HOSPITALITY COMM MATE | 07/26/2021 | 38.74 | 02/22 | 430-23-42-5222-318 |
| Total 072621: | | | | | 38.74 | | |
| Total DOHMS, MARK (4064): | | | | | 38.74 | | |
| DON'S PEST CONTROL (3349) | | | | | | | |
| 2725 | 1 | Invoice | PEST CONTROL | 07/12/2021 | 46.00 | 02/22 | 602-23-61-5651-299 |
| Total 2725: | | | | | 46.00 | | |
| Total DON'S PEST CONTROL (3349): | | | | | 46.00 | | |
| EDWARD JONES (7339) | | | | | | | |
| 072321 | 1 | Invoice | REIMBURSE/LIGHTING REBATE | 07/23/2021 | 1,000.00 | 02/22 | 601-23-53-5588-212 |
| Total 072321: | | | | | 1,000.00 | | |
| Total EDWARD JONES (7339): | | | | | 1,000.00 | | |
| EMILY HANSEN (7344) | | | | | | | |
| 222-5424 | 1 | Invoice | YOUTH TRACK COACH - CONTRACTED SVC | 06/01/2021 | 400.00 | 12/21 | 100-22-42-5222-299 |
| Total 222-5424: | | | | | 400.00 | | |

| Invoice | Seq | Type | Description | Invoice Date | Total Cost | Period | GL Account |
|---|-----|---------|------------------------------------|--------------|------------|--------|--------------------|
| Total EMILY HANSEN (7344): | | | | | 400.00 | | |
| FASTENAL COMPANY (3509) | | | | | | | |
| 1AFTD23634 | 1 | Invoice | 5=3XL & 5=2XL COVERALLS | 07/06/2021 | 66.14 | 02/22 | 204-23-30-5310-312 |
| 1AFTD23634 | 2 | Invoice | 5=3XL & 5=2XL COVERALLS | 07/06/2021 | 20.13 | 02/22 | 602-23-62-5662-312 |
| 1AFTD23634 | 3 | Invoice | 5=3XL & 5=2XL COVERALLS | 07/06/2021 | 9.58 | 02/22 | 603-23-71-5662-312 |
| Total 1AFTD236343: | | | | | 95.85 | | |
| Total FASTENAL COMPANY (3509): | | | | | 95.85 | | |
| FLETCHER-REINHARDT COMPANY (305) | | | | | | | |
| S1250613.00 | 1 | Invoice | 7= SECONDARY PEDESTALS | 07/15/2021 | 1,647.80 | 01/22 | 601-23-52-5588-318 |
| Total S1250613.001: | | | | | 1,647.80 | | |
| S1250803.00 | 1 | Invoice | SLEEVES & HYSPLICE | 07/16/2021 | 465.03 | 01/22 | 601-23-52-5588-318 |
| Total S1250803.001: | | | | | 465.03 | | |
| Total FLETCHER-REINHARDT COMPANY (305): | | | | | 2,112.83 | | |
| FORCE FLOW (2711) | | | | | | | |
| 37803 | 1 | Invoice | REPLACEMENT LOAD CELL FOR CHLOR-SC | 07/13/2021 | 522.25 | 01/22 | 603-23-70-5642-318 |
| Total 37803: | | | | | 522.25 | | |
| Total FORCE FLOW (2711): | | | | | 522.25 | | |
| GORDON FLESCH COMPANY (6978) | | | | | | | |
| IN13397492 | 1 | Invoice | CANON/IR C350IF | 07/19/2021 | 15.19 | 02/22 | 100-24-14-5435-225 |
| IN13397492 | 2 | Invoice | CANON/IR C350IF | 07/19/2021 | 109.72 | 02/22 | 601-23-80-5931-225 |
| IN13397492 | 3 | Invoice | CANON/IR C350IF | 07/19/2021 | 33.76 | 02/22 | 602-23-80-5931-225 |
| IN13397492 | 4 | Invoice | CANON/IR C350IF | 07/19/2021 | 10.13 | 02/22 | 603-23-80-5931-225 |
| Total IN13397492: | | | | | 168.80 | | |
| Total GORDON FLESCH COMPANY (6978): | | | | | 168.80 | | |
| GRAVOS, TAYLOR (7342) | | | | | | | |
| 1416267113 | 1 | Invoice | CUSTOMER DEPOSIT REFUND | 07/21/2021 | 98.30 | 02/22 | 601-21011 |
| Total 1416267113: | | | | | 98.30 | | |
| Total GRAVOS, TAYLOR (7342): | | | | | 98.30 | | |
| GRIMES ASPHALT & PAVING CORP. (1837) | | | | | | | |
| 20775 | 1 | Invoice | Cold mix 8.05T | 07/14/2021 | 1,175.30 | 01/22 | 204-23-30-5310-318 |
| Total 20775: | | | | | 1,175.30 | | |
| Total GRIMES ASPHALT & PAVING CORP. (1837): | | | | | 1,175.30 | | |
| HAWKEYE WEST PEST CONTROL (7345) | | | | | | | |
| 31880 | 1 | Invoice | PEST CONTROL STREET DEPT | 07/01/2021 | 65.00 | 01/22 | 204-23-30-5310-299 |
| Total 31880: | | | | | 65.00 | | |

| Invoice | Seq | Type | Description | Invoice Date | Total Cost | Period | GL Account |
|---|-----|---------|-----------------------------------|--------------|------------|--------|--------------------|
| Total HAWKEYE WEST PEST CONTROL (7345): | | | | | 65.00 | | |
| HAWKINS, INC. (3668) | | | | | | | |
| 4977316 | 1 | Invoice | AQUA HAWK 607 | 07/07/2021 | 750.88 | 02/22 | 602-23-61-5641-318 |
| Total 4977316: | | | | | 750.88 | | |
| 4977384 | 1 | Invoice | Chlorine & SODIUM BISULFITE | 07/07/2021 | 1,602.06 | 01/22 | 603-23-70-5641-318 |
| Total 4977384: | | | | | 1,602.06 | | |
| 4985329 | 1 | Invoice | Chlorine & PHOSPHATE | 07/16/2021 | 4,619.36 | 01/22 | 602-23-61-5641-318 |
| Total 4985329: | | | | | 4,619.36 | | |
| Total HAWKINS, INC. (3668): | | | | | 6,972.30 | | |
| HOLLINGSHEAD, LUANA (6929) | | | | | | | |
| 072621 | 1 | Invoice | JANITORIAL SVC-SR CTR-AUGUST 2021 | 07/26/2021 | 240.00 | 02/22 | 100-22-42-5280-299 |
| Total 072621: | | | | | 240.00 | | |
| Total HOLLINGSHEAD, LUANA (6929): | | | | | 240.00 | | |
| HOLMES MURPHY & ASSOCIATES, LLC (5556) | | | | | | | |
| 604073 | 1 | Invoice | HOLMES MURPHY FEES-AUGUST 2021 | 07/20/2021 | 2,380.00 | 02/22 | 902-11215 |
| Total 604073: | | | | | 2,380.00 | | |
| Total HOLMES MURPHY & ASSOCIATES, LLC (5556): | | | | | 2,380.00 | | |
| HOOKER, MICHELLE (3453) | | | | | | | |
| 070121 | 1 | Invoice | ENERGY EFFICIENCY REBATE | 07/01/2021 | 75.00 | 02/22 | 601-23-36-5930-979 |
| 070121 | 2 | Invoice | ENERGY EFFICIENCY REBATE | 07/01/2021 | 75.00 | 02/22 | 601-23-36-5930-979 |
| 070121 | 3 | Invoice | ENERGY EFFICIENCY REBATE | 07/01/2021 | 50.00 | 02/22 | 601-23-36-5930-979 |
| 070121 | 4 | Invoice | CORN BELT A/C REBATE | 07/01/2021 | 100.00 | 02/22 | 601-23-53-5930-979 |
| Total 070121: | | | | | 300.00 | | |
| Total HOOKER, MICHELLE (3453): | | | | | 300.00 | | |
| HOWARD, JESS (5722) | | | | | | | |
| 222-5423 | 1 | Invoice | YOUTH SOFTBALL | 07/21/2021 | 1,000.00 | 01/22 | 100-22-42-5222-299 |
| Total 222-5423: | | | | | 1,000.00 | | |
| Total HOWARD, JESS (5722): | | | | | 1,000.00 | | |
| inTANDEM (6526) | | | | | | | |
| 2196 | 1 | Invoice | RETAINER/AUGUST 2021 | 06/10/2021 | 488.00 | 02/22 | 100-24-12-5430-299 |
| 2196 | 2 | Invoice | RETAINER/AUGUST 2021 | 06/10/2021 | 1,342.00 | 02/22 | 601-23-81-5930-299 |
| 2196 | 3 | Invoice | RETAINER/AUGUST 2021 | 06/10/2021 | 305.00 | 02/22 | 602-23-81-5930-299 |
| 2196 | 4 | Invoice | RETAINER/AUGUST 2021 | 06/10/2021 | 305.00 | 02/22 | 603-23-81-5930-299 |
| Total 2196: | | | | | 2,440.00 | | |
| Total inTANDEM (6526): | | | | | 2,440.00 | | |

| Invoice | Seq | Type | Description | Invoice Date | Total Cost | Period | GL Account |
|---|-----|---------|--|--------------|------------|--------|--------------------|
| IOWA ONE CALL (485) | | | | | | | |
| 232929 | 1 | Invoice | ONE CALL SERVICES | 07/15/2021 | 66.44 | 12/21 | 601-23-52-5930-299 |
| 232929 | 2 | Invoice | ONE CALL SERVICES | 07/15/2021 | 45.73 | 12/21 | 602-23-62-5662-299 |
| 232929 | 3 | Invoice | ONE CALL SERVICES | 07/15/2021 | 45.73 | 12/21 | 603-23-71-5662-299 |
| Total 232929: | | | | | 157.90 | | |
| Total IOWA ONE CALL (485): | | | | | 157.90 | | |
| IOWA PLAINS SIGNING, INC. (487) | | | | | | | |
| 48278 | 1 | Invoice | ARROW & HANDICAP STENCILS | 07/12/2021 | 650.00 | 01/22 | 100-21-30-5120-318 |
| Total 48278: | | | | | 650.00 | | |
| Total IOWA PLAINS SIGNING, INC. (487): | | | | | 650.00 | | |
| IOWA RURAL WATER ASSOCIATION (491) | | | | | | | |
| E15152-6731 | 1 | Invoice | WATER DIST - 2021 FALL CONF (BRANDON/Z | 07/14/2021 | 480.00 | 02/22 | 602-23-62-5926-231 |
| Total E15152-673128: | | | | | 480.00 | | |
| E15152-6740 | 1 | Invoice | FALL CONF REG / T.CHAMBERS | 07/28/2021 | 160.00 | 02/22 | 602-23-61-5926-231 |
| E15152-6740 | 2 | Invoice | FALL CONF REG / J.JACKSON | 07/28/2021 | 160.00 | 02/22 | 603-23-70-5926-231 |
| Total E15152-674079: | | | | | 320.00 | | |
| Total IOWA RURAL WATER ASSOCIATION (491): | | | | | 800.00 | | |
| KERRICK, SHAWN (5176) | | | | | | | |
| 060621 | 1 | Invoice | ENERGY EFFICIENCY REBATE | 06/06/2021 | 75.00 | 12/21 | 601-23-36-5930-979 |
| 060621 | 2 | Invoice | CB EE RESIDENTIAL REBATE | 06/06/2021 | 25.00 | 12/21 | 601-23-53-5930-979 |
| Total 060621: | | | | | 100.00 | | |
| Total KERRICK, SHAWN (5176): | | | | | 100.00 | | |
| LAMPERT'S (564) | | | | | | | |
| 908836 | 1 | Invoice | 2 = 2X10X20' - WATERMAIN MAINT. | 07/12/2021 | 146.74 | 01/22 | 602-23-62-5662-318 |
| Total 908836: | | | | | 146.74 | | |
| 927851 | 1 | Invoice | W.TWIN GALV ROOF APRON BROWN (MATT | 07/23/2021 | 119.36 | 01/22 | 100-22-42-5210-880 |
| Total 927851: | | | | | 119.36 | | |
| 927884 | 1 | Invoice | J.HAWKINS - W TWIN SHELTER | 07/23/2021 | 419.97 | 01/22 | 100-22-42-5210-880 |
| Total 927884: | | | | | 419.97 | | |
| Total LAMPERT'S (564): | | | | | 686.07 | | |
| LEHMAN, MICHAEL (6775) | | | | | | | |
| 071521 | 1 | Invoice | MILEAGE EXP/CPR TRAINING | 07/15/2021 | 25.20 | 02/22 | 100-21-21-5110-231 |
| Total 071521: | | | | | 25.20 | | |
| Total LEHMAN, MICHAEL (6775): | | | | | 25.20 | | |

| Invoice | Seq | Type | Description | Invoice Date | Total Cost | Period | GL Account |
|---|-----|---------|---------------------------------------|--------------|------------|--------|--------------------|
| LENOVO (UNITED STATES) INC. (3779) | | | | | | | |
| 6457631723 | 1 | Invoice | LAPTOPS (2) | 06/12/2021 | 706.62 | 12/21 | 100-24-16-5420-317 |
| 6457631723 | 2 | Invoice | LAPTOPS (2) | 06/12/2021 | 2,590.94 | 12/21 | 601-24-16-5921-317 |
| 6457631723 | 3 | Invoice | LAPTOPS (2) | 06/12/2021 | 706.62 | 12/21 | 602-24-16-5921-317 |
| 6457631723 | 4 | Invoice | LAPTOPS (2) | 06/12/2021 | 706.62 | 12/21 | 603-24-16-5921-317 |
| Total 6457631723: | | | | | 4,710.80 | | |
| 6457631724 | 1 | Invoice | LAPTOP FOR IT | 06/12/2021 | 390.73 | 12/21 | 100-24-16-5420-317 |
| 6457631724 | 2 | Invoice | LAPTOP FOR IT | 06/12/2021 | 1,432.64 | 12/21 | 601-24-16-5921-317 |
| 6457631724 | 3 | Invoice | LAPTOP FOR IT | 06/12/2021 | 390.73 | 12/21 | 602-24-16-5921-317 |
| 6457631724 | 4 | Invoice | LAPTOP FOR IT | 06/12/2021 | 390.73 | 12/21 | 603-24-16-5921-317 |
| Total 6457631724: | | | | | 2,604.83 | | |
| Total LENOVO (UNITED STATES) INC. (3779): | | | | | 7,315.63 | | |
| MAVERICK MACHINE TOOL (1512) | | | | | | | |
| 7648 | 1 | Invoice | MACHINE HUB & SHAFT FOR BALL JOINTS F | 07/06/2021 | 267.50 | 01/22 | 602-23-61-5935-227 |
| Total 7648: | | | | | 267.50 | | |
| Total MAVERICK MACHINE TOOL (1512): | | | | | 267.50 | | |
| MECHANICAL COMFORT, INC. (618) | | | | | | | |
| 42493 | 1 | Invoice | LABOR ON AIR MAKEUP UNITS | 06/30/2021 | 216.25 | 12/21 | 603-23-70-5935-227 |
| Total 42493: | | | | | 216.25 | | |
| 42494 | 1 | Invoice | LABOR ON AIR MAKEUP UNITS | 06/30/2021 | 88.20 | 12/21 | 603-23-70-5935-227 |
| Total 42494: | | | | | 88.20 | | |
| 42573 | 1 | Invoice | BOILER MAINTENANCE | 07/22/2021 | 314.28 | 12/21 | 100-24-36-5480-226 |
| 42573 | 2 | Invoice | BOILER MAINTENANCE | 07/22/2021 | 224.49 | 12/21 | 601-23-36-5480-226 |
| 42573 | 3 | Invoice | BOILER MAINTENANCE | 07/22/2021 | 179.59 | 12/21 | 602-23-36-5480-226 |
| 42573 | 4 | Invoice | BOILER MAINTENANCE | 07/22/2021 | 179.59 | 12/21 | 603-23-36-5480-226 |
| Total 42573: | | | | | 897.95 | | |
| Total MECHANICAL COMFORT, INC. (618): | | | | | 1,202.40 | | |
| MEDIACOM (5464) | | | | | | | |
| 071621 | 1 | Invoice | DIGITAL BOX RENTAL | 07/16/2021 | 7.86 | 02/22 | 100-21-21-5110-230 |
| Total 071621: | | | | | 7.86 | | |
| Total MEDIACOM (5464): | | | | | 7.86 | | |
| MENARDS (622) | | | | | | | |
| 51416 | 1 | Invoice | SIDING MATERIAL GSR BLDG | 07/20/2021 | 12.99 | 01/22 | 602-23-61-5651-310 |
| Total 51416: | | | | | 12.99 | | |
| 51817 | 1 | Invoice | MULCH FOR LANDSCAPE | 07/10/2021 | 22.10 | 02/22 | 100-21-22-5140-318 |
| Total 51817: | | | | | 22.10 | | |

| Invoice | Seq | Type | Description | Invoice Date | Total Cost | Period | GL Account |
|---|-----|---------|----------------------------------|--------------|------------|--------|--------------------|
| 51999 | 1 | Invoice | SIDING MATERIAL GSR BLDG | 07/13/2021 | 56.85 | 01/22 | 602-23-61-5651-310 |
| Total 51999: | | | | | 56.85 | | |
| 52414 | 1 | Invoice | SIDING MATERIAL GSR BLDG | 07/20/2021 | 28.95 | 01/22 | 602-23-61-5651-310 |
| Total 52414: | | | | | 28.95 | | |
| 52479 | 1 | Invoice | LINE DEPT | 07/21/2021 | 11.40 | 01/22 | 601-23-52-5588-318 |
| 52479 | 2 | Invoice | W TWIN SHELTER MATERIALS | 07/21/2021 | 101.79 | 01/22 | 100-22-42-5210-880 |
| Total 52479: | | | | | 113.19 | | |
| 52644 | 1 | Invoice | ICE & WATER WEATHERLOCK - W.TWIN | 07/23/2021 | 239.97 | 01/22 | 100-22-42-5210-880 |
| Total 52644: | | | | | 239.97 | | |
| Total MENARDS (622): | | | | | 474.05 | | |
| MOORE CLEANING SERVICE, LLC (2902) | | | | | | | |
| 072621 | 1 | Invoice | CLEANING SERVICES FOR CITY HALL | 07/26/2021 | 455.00 | 02/22 | 100-24-36-5480-299 |
| 072621 | 2 | Invoice | CLEANING SERVICES FOR CITY HALL | 07/26/2021 | 325.00 | 02/22 | 601-23-36-5480-299 |
| 072621 | 3 | Invoice | CLEANING SERVICES FOR CITY HALL | 07/26/2021 | 260.00 | 02/22 | 602-23-36-5480-299 |
| 072621 | 4 | Invoice | CLEANING SERVICES FOR CITY HALL | 07/26/2021 | 260.00 | 02/22 | 603-23-36-5480-299 |
| Total 072621: | | | | | 1,300.00 | | |
| Total MOORE CLEANING SERVICE, LLC (2902): | | | | | 1,300.00 | | |
| NAPA AUTO PARTS (677) | | | | | | | |
| 922750 | 1 | Invoice | FT BLAC | 07/12/2021 | 24.24 | 01/22 | 204-23-30-5310-314 |
| Total 922750: | | | | | 24.24 | | |
| 922965 | 1 | Invoice | WHEEL NUTS - OIL FILTERS & OIL | 07/15/2021 | 71.50 | 01/22 | 204-23-30-5310-314 |
| Total 922965: | | | | | 71.50 | | |
| 923334 | 1 | Invoice | GAS CAP FOR SWEEPER | 07/21/2021 | 7.54 | 01/22 | 100-23-30-5350-314 |
| Total 923334: | | | | | 7.54 | | |
| 923417 | 1 | Invoice | WINDSHIELD WASHER & OIL FILTER | 07/22/2021 | 24.62 | 01/22 | 204-23-30-5310-314 |
| Total 923417: | | | | | 24.62 | | |
| Total NAPA AUTO PARTS (677): | | | | | 127.90 | | |
| NCL OF WISCONSIN, INC. (687) | | | | | | | |
| 456855 | 1 | Invoice | TESTING SUPPLIES | 07/07/2021 | 17.34 | 01/22 | 603-23-70-5642-319 |
| Total 456855: | | | | | 17.34 | | |
| 457401 | 1 | Invoice | TESTING SUPPLIES | 07/20/2021 | 1,069.39 | 01/22 | 603-23-70-5642-319 |
| Total 457401: | | | | | 1,069.39 | | |

| Invoice | Seq | Type | Description | Invoice Date | Total Cost | Period | GL Account |
|--|-----|---------|--------------------------------------|--------------|------------|--------|--------------------|
| Total NCL OF WISCONSIN, INC. (687): | | | | | 1,086.73 | | |
| NORTHERN BALANCE & SCALE (706) | | | | | | | |
| 00126103 | 1 | Invoice | CALIBRATE & SERVICE BALANCE/SCALE | 07/09/2021 | 312.00 | 01/22 | 603-23-70-5653-299 |
| Total 00126103: | | | | | 312.00 | | |
| Total NORTHERN BALANCE & SCALE (706): | | | | | 312.00 | | |
| O'HALLORAN INTERNATIONAL (718) | | | | | | | |
| 31P120167 | 1 | Invoice | REMAN HEATER / A/C | 07/09/2021 | 541.34 | 01/22 | 204-23-30-5310-314 |
| Total 31P120167: | | | | | 541.34 | | |
| 34P10540 | 1 | Invoice | COOLANT RESERVOR CAP | 07/20/2021 | 62.87 | 01/22 | 204-23-30-5310-314 |
| Total 34P10540: | | | | | 62.87 | | |
| Total O'HALLORAN INTERNATIONAL (718): | | | | | 604.21 | | |
| O'REILLY AUTOMOTIVE, INC. (727) | | | | | | | |
| 0357-100425 | 1 | Invoice | VENT STICK FOR VAN | 07/15/2021 | 3.29 | 01/22 | 601-23-51-5935-314 |
| 0357-100425 | 2 | Invoice | SCREW SET (COUNCIL TV's) | 07/15/2021 | 2.80 | 01/22 | 100-24-36-5480-318 |
| 0357-100425 | 3 | Invoice | SCREW SET (COUNCIL TV's) | 07/15/2021 | 1.99 | 01/22 | 601-23-36-5480-318 |
| 0357-100425 | 4 | Invoice | SCREW SET (COUNCIL TV's) | 07/15/2021 | 1.60 | 01/22 | 602-23-36-5480-318 |
| 0357-100425 | 5 | Invoice | SCREW SET (COUNCIL TV's) | 07/15/2021 | 1.60 | 01/22 | 603-23-36-5480-318 |
| 0357-100425 | 6 | Invoice | TAX | 07/15/2021 | .79 | 01/22 | 601-23-51-5935-314 |
| Total 0357-100425: | | | | | 12.07 | | |
| 0357-100559 | 1 | Invoice | PROTECTANT/GLASS CLEANER | 07/16/2021 | 15.98 | 02/22 | 100-21-22-5140-318 |
| Total 0357-100559: | | | | | 15.98 | | |
| 0357-101121 | 1 | Invoice | GAUGE/CLEANER | 07/23/2021 | 115.67 | 02/22 | 100-21-21-5110-314 |
| Total 0357-101121: | | | | | 115.67 | | |
| Total O'REILLY AUTOMOTIVE, INC. (727): | | | | | 143.72 | | |
| PATHFINDERS STRATEGIC PARTNERS (7251) | | | | | | | |
| 0721135 | 1 | Invoice | FY 2022 PLANNING SECTION ANNUAL DUES | 07/01/2021 | 7,921.66 | 02/22 | 100-24-18-5470-215 |
| Total 0721135: | | | | | 7,921.66 | | |
| Total PATHFINDERS STRATEGIC PARTNERS (7251): | | | | | 7,921.66 | | |
| PITNEY BOWES-RESERVE ACCT (758) | | | | | | | |
| 072621 | 1 | Invoice | PREPAID POSTAGE | 07/26/2021 | 3,000.00 | 02/22 | 100-11210 |
| Total 072621: | | | | | 3,000.00 | | |
| Total PITNEY BOWES-RESERVE ACCT (758): | | | | | 3,000.00 | | |
| PRINTING SERVICES, INC. (1130) | | | | | | | |
| 692797-0 | 1 | Invoice | MISC OFFICE SUPPLIES | 06/16/2021 | 87.02 | 12/21 | 100-21-18-5190-316 |

| Invoice | Seq | Type | Description | Invoice Date | Total Cost | Period | GL Account |
|--|-----|---------|--------------------------------------|--------------|------------|--------|--------------------|
| Total 692797-0: | | | | | 87.02 | | |
| 692851-0 | 1 | Invoice | MISC OFFICE SUPPLIES | 06/18/2021 | 37.28 | 12/21 | 100-24-12-5430-316 |
| 692851-0 | 2 | Invoice | MISC OFFICE SUPPLIES | 06/18/2021 | 102.48 | 12/21 | 601-23-81-5921-316 |
| 692851-0 | 3 | Invoice | MISC OFFICE SUPPLIES | 06/18/2021 | 23.29 | 12/21 | 602-23-81-5921-316 |
| 692851-0 | 4 | Invoice | MISC OFFICE SUPPLIES | 06/18/2021 | 23.29 | 12/21 | 603-23-81-5921-316 |
| Total 692851-0: | | | | | 186.34 | | |
| 693209-0 | 1 | Invoice | PENS/INDEX CARDS/SPECIALTY PAPER | 07/08/2021 | 10.23 | 12/21 | 100-24-14-5435-316 |
| 693209-0 | 2 | Invoice | PENS/INDEX CARDS/SPECIALTY PAPER | 07/08/2021 | 73.89 | 12/21 | 601-23-80-5921-316 |
| 693209-0 | 3 | Invoice | PENS/INDEX CARDS/SPECIALTY PAPER | 07/08/2021 | 22.73 | 12/21 | 602-23-80-5921-316 |
| 693209-0 | 4 | Invoice | PENS/INDEX CARDS/SPECIALTY PAPER | 07/08/2021 | 6.82 | 12/21 | 603-23-80-5921-316 |
| Total 693209-0: | | | | | 113.67 | | |
| Total PRINTING SERVICES, INC. (1130): | | | | | 387.03 | | |
| R & J MATERIAL HANDLING (3205) | | | | | | | |
| 01-83363 | 1 | Invoice | PARTS FOR KUBOTA MOWERS | 07/19/2021 | 404.26 | 01/22 | 100-22-42-5210-314 |
| 01-83363 | 2 | Invoice | PARTS FOR KUBOTA MOWERS | 07/19/2021 | 404.25 | 01/22 | 100-23-42-5371-314 |
| Total 01-83363: | | | | | 808.51 | | |
| Total R & J MATERIAL HANDLING (3205): | | | | | 808.51 | | |
| SCHLOTFELDT ENGINEERING, INC. (836) | | | | | | | |
| 27747 | 1 | Invoice | PLANS & SPECS FOR COURTHOUSE @ W.B | 07/27/2021 | 14,925.00 | 12/21 | 534-23-42-5221-212 |
| Total 27747: | | | | | 14,925.00 | | |
| Total SCHLOTFELDT ENGINEERING, INC. (836): | | | | | 14,925.00 | | |
| SKARSHAUG TESTING LAB, INC. (878) | | | | | | | |
| 253040 | 1 | Invoice | CLEAN & TEST GLOVES & SLEEVES | 07/08/2021 | 367.68 | 01/22 | 601-23-52-5935-227 |
| Total 253040: | | | | | 367.68 | | |
| Total SKARSHAUG TESTING LAB, INC. (878): | | | | | 367.68 | | |
| SNYDER & ASSOCIATES (2951) | | | | | | | |
| 121.0372.01- | 1 | Invoice | ENG - 2021 HMA ST IMPROVEMENTS PROJE | 07/21/2021 | 17,463.56 | 12/21 | 525-23-30-5310-212 |
| Total 121.0372.01-3: | | | | | 17,463.56 | | |
| Total SNYDER & ASSOCIATES (2951): | | | | | 17,463.56 | | |
| STATE HYGIENIC LABORATORY (423) | | | | | | | |
| 211971 | 1 | Invoice | WASTEWATER TESTING | 06/30/2021 | 1,465.50 | 12/21 | 603-23-70-5923-212 |
| Total 211971: | | | | | 1,465.50 | | |
| 211972 | 1 | Invoice | WATER PLANT TESTING | 06/30/2021 | 261.50 | 12/21 | 602-23-61-5642-299 |
| Total 211972: | | | | | 261.50 | | |

| Invoice | Seq | Type | Description | Invoice Date | Total Cost | Period | GL Account |
|---|-----|---------|-------------------------------------|--------------|------------|--------|--------------------|
| Total STATE HYGIENIC LABORATORY (423): | | | | | 1,727.00 | | |
| STORM FLYING SERVICE, INC. (911) | | | | | | | |
| 072621 | 1 | Invoice | AIRPORT MANAGER FEE - AUGUST 2021 | 07/26/2021 | 3,889.97 | 02/22 | 205-23-45-5372-299 |
| 072621 | 2 | Invoice | ADJ - JULY MANAGER FEE | 07/26/2021 | 113.30 | 02/22 | 205-23-45-5372-299 |
| Total 072621: | | | | | 4,003.27 | | |
| Total STORM FLYING SERVICE, INC. (911): | | | | | 4,003.27 | | |
| STRUCHEN, STEVE (4980) | | | | | | | |
| 072621 | 1 | Invoice | REIMBURSEMENT RAGBRAI SIGNS | 07/26/2021 | 373.19 | 02/22 | 430-23-42-5222-318 |
| Total 072621: | | | | | 373.19 | | |
| Total STRUCHEN, STEVE (4980): | | | | | 373.19 | | |
| SYNC/AMAZON (6343) | | | | | | | |
| 4533569497 | 1 | Invoice | LIGHT BAR/SQUAD #8 | 07/02/2021 | 119.99 | 02/22 | 100-21-21-5110-227 |
| Total 453356949783: | | | | | 119.99 | | |
| 4646453555 | 1 | Invoice | OTTERBOX FOR IPAD-INSP | 06/18/2021 | 13.13 | 12/21 | 100-24-16-5420-317 |
| 4646453555 | 2 | Invoice | OTTERBOX FOR IPAD-INSP | 06/18/2021 | 48.16 | 12/21 | 601-24-16-5921-317 |
| 4646453555 | 3 | Invoice | OTTERBOX FOR IPAD-INSP | 06/18/2021 | 13.13 | 12/21 | 602-24-16-5921-317 |
| 4646453555 | 4 | Invoice | OTTERBOX FOR IPAD-INSP | 06/18/2021 | 13.13 | 12/21 | 603-24-16-5921-317 |
| Total 464645355548: | | | | | 87.55 | | |
| 4649363468 | 1 | Invoice | INK CARTRIDGE | 06/24/2021 | 60.41 | 12/21 | 100-24-18-5470-316 |
| Total 464936346855: | | | | | 60.41 | | |
| 4676447779 | 1 | Invoice | HDMI CABLES/TVS IN COUNCIL CHAMBERS | 07/08/2021 | 25.95 | 02/22 | 100-24-16-5420-317 |
| 4676447779 | 2 | Invoice | HDMI CABLES/TVS IN COUNCIL CHAMBERS | 07/08/2021 | 95.12 | 02/22 | 601-24-16-5921-317 |
| 4676447779 | 3 | Invoice | HDMI CABLES/TVS IN COUNCIL CHAMBERS | 07/08/2021 | 25.95 | 02/22 | 602-24-16-5921-317 |
| 4676447779 | 4 | Invoice | HDMI CABLES/TVS IN COUNCIL CHAMBERS | 07/08/2021 | 25.95 | 02/22 | 603-24-16-5921-317 |
| Total 467644777984: | | | | | 172.97 | | |
| 5733574888 | 1 | Invoice | KEYBOARDS/MICE | 06/10/2021 | 11.16 | 12/21 | 100-24-16-5420-317 |
| 5733574888 | 2 | Invoice | KEYBOARDS/MICE | 06/10/2021 | 40.92 | 12/21 | 601-24-16-5921-317 |
| 5733574888 | 3 | Invoice | KEYBOARDS/MICE | 06/10/2021 | 11.16 | 12/21 | 602-24-16-5921-317 |
| 5733574888 | 4 | Invoice | KEYBOARDS/MICE | 06/10/2021 | 11.16 | 12/21 | 603-24-16-5921-317 |
| Total 573357488856: | | | | | 74.40 | | |
| 5744468553 | 1 | Invoice | ANTENNA MOUNT REPAIR KIT/SQUAD #6 | 07/02/2021 | 18.55 | 02/22 | 100-21-21-5110-227 |
| Total 574446855384: | | | | | 18.55 | | |
| 6765995569 | 1 | Invoice | BRACKETS/STROBE LIGHT BAR/SQUAD #8 | 07/02/2021 | 299.95 | 02/22 | 100-21-21-5110-227 |
| Total 676599556948: | | | | | 299.95 | | |
| 6946499489 | 1 | Invoice | COAX ADAPTERS/CAR #3 | 06/25/2021 | 20.98 | 12/21 | 100-21-21-5110-227 |

| Invoice | Seq | Type | Description | Invoice Date | Total Cost | Period | GL Account |
|--|-----|---------|--|--------------|------------|--------|--------------------|
| Total 694649948968: | | | | | 20.98 | | |
| 8359844683 | 1 | Invoice | HOLE MAGNETS/SEAT ORGANIZER/CAR #3 | 07/02/2021 | 44.94 | 02/22 | 100-21-21-5110-227 |
| Total 835984468348: | | | | | 44.94 | | |
| 8773963478 | 1 | Invoice | ANTENNA/COAX ADAPTER/CAR #3 | 06/22/2021 | 36.04 | 12/21 | 100-21-21-5110-227 |
| Total 877396347845: | | | | | 36.04 | | |
| 8998849735 | 1 | Invoice | WRISTBANDS/NAT'L NIGHT OUT | 07/08/2021 | 107.56 | 02/22 | 100-21-21-5110-318 |
| Total 899884973599: | | | | | 107.56 | | |
| 9845668859 | 1 | Invoice | INK CARTRIDGE | 06/24/2021 | 101.83 | 12/21 | 100-24-18-5470-316 |
| Total 984566885974: | | | | | 101.83 | | |
| 9846967444 | 1 | Invoice | CARRYCASES FOR LAPTOPS | 06/10/2021 | 11.51 | 12/21 | 100-24-16-5420-317 |
| 9846967444 | 2 | Invoice | CARRYCASES FOR LAPTOPS | 06/10/2021 | 42.24 | 12/21 | 601-24-16-5921-317 |
| 9846967444 | 3 | Invoice | CARRYCASES FOR LAPTOPS | 06/10/2021 | 11.51 | 12/21 | 602-24-16-5921-317 |
| 9846967444 | 4 | Invoice | CARRYCASES FOR LAPTOPS | 06/10/2021 | 11.51 | 12/21 | 603-24-16-5921-317 |
| Total 984696744438: | | | | | 76.77 | | |
| Total SYNC/AMAZON (6343): | | | | | 1,221.94 | | |
| TEN 13 PROPERTIES (7338) | | | | | | | |
| 1413900002 | 1 | Invoice | CUSTOMER DEPOSIT REFUND | 07/23/2021 | 181.20 | 02/22 | 601-21011 |
| Total 1413900002: | | | | | 181.20 | | |
| Total TEN 13 PROPERTIES (7338): | | | | | 181.20 | | |
| THE IOWA OUTDOORS STORE, LLC (7104) | | | | | | | |
| 25807/1 | 1 | Invoice | PARTS FOR MOWERS | 07/19/2021 | 282.15 | 01/22 | 100-23-42-5371-314 |
| 25807/1 | 2 | Invoice | PARTS FOR MOWERS | 07/19/2021 | 282.14 | 01/22 | 100-22-42-5210-314 |
| Total 25807/1: | | | | | 564.29 | | |
| Total THE IOWA OUTDOORS STORE, LLC (7104): | | | | | 564.29 | | |
| TMI SERVICES, INC. (954) | | | | | | | |
| 12209 | 1 | Invoice | HANDICAP PORTABLE TOILET - DEPOT ONL | 07/14/2021 | 100.00 | 12/21 | 100-22-42-5221-225 |
| 12209 | 2 | Invoice | PORTABLE TOILET RENTAL JUNE 2021- VARI | 07/14/2021 | 320.00 | 12/21 | 100-22-42-5210-225 |
| Total 12209: | | | | | 420.00 | | |
| Total TMI SERVICES, INC. (954): | | | | | 420.00 | | |
| TOLLE AUTOMOTIVE, INC. (3188) | | | | | | | |
| 18252 | 1 | Invoice | TIRE REPAIR/TAHOE 4 | 07/06/2021 | 60.00 | 02/22 | 100-21-21-5110-227 |
| Total 18252: | | | | | 60.00 | | |
| 18335 | 1 | Invoice | MOUNT & BALANCE/TAHOE #3 | 07/16/2021 | 107.12 | 02/22 | 100-21-21-5110-227 |

| Invoice | Seq | Type | Description | Invoice Date | Total Cost | Period | GL Account |
|--|-----|---------|---------------------------|--------------|------------|--------|--------------------|
| Total 18335: | | | | | 107.12 | | |
| 19887 | 1 | Invoice | TIRE CHANGE | 07/15/2021 | 85.00 | 02/22 | 100-21-21-5110-227 |
| Total 19887: | | | | | 85.00 | | |
| Total TOLLE AUTOMOTIVE, INC. (3188): | | | | | 252.12 | | |
| VALUTECH PEST CONTROL (6822) | | | | | | | |
| 1529 | 1 | Invoice | DOWNTOWN AREA-CO-OP/SSMID | 07/23/2021 | 65.00 | 02/22 | 260-23-36-5393-299 |
| Total 1529: | | | | | 65.00 | | |
| Total VALUTECH PEST CONTROL (6822): | | | | | 65.00 | | |
| VERIZON WIRELESS (3812) | | | | | | | |
| 9883822069 | 1 | Invoice | GPS UNIT PHONE | 07/10/2021 | 40.01 | 02/22 | 100-23-31-5420-230 |
| 9883822069 | 2 | Invoice | GPS UNIT PHONE | 07/10/2021 | 40.01 | 02/22 | 601-23-31-5420-230 |
| 9883822069 | 3 | Invoice | GPS UNIT PHONE | 07/10/2021 | 40.01 | 02/22 | 602-23-31-5420-230 |
| 9883822069 | 4 | Invoice | GPS UNIT PHONE | 07/10/2021 | 40.01 | 02/22 | 603-23-31-5420-230 |
| Total 9883822069: | | | | | 160.04 | | |
| Total VERIZON WIRELESS (3812): | | | | | 160.04 | | |
| VERMEER SALES & SERVICE INC. (6073) | | | | | | | |
| 01175415 | 1 | Invoice | HYD REMOTE | 07/12/2021 | 824.00 | 01/22 | 601-23-52-5935-314 |
| Total 01175415: | | | | | 824.00 | | |
| Total VERMEER SALES & SERVICE INC. (6073): | | | | | 824.00 | | |
| WEBSTER CITY TRUE VALUE (2155) | | | | | | | |
| 154292 | 1 | Invoice | CAULK | 07/03/2021 | 4.89 | 01/22 | 602-23-61-5642-318 |
| Total 154292: | | | | | 4.89 | | |
| 154583 | 1 | Invoice | CABLE FOR COUNCIL TV's | 07/16/2021 | 45.14 | 01/22 | 100-24-36-5480-318 |
| 154583 | 2 | Invoice | CABLE FOR COUNCIL TV's | 07/16/2021 | 32.25 | 01/22 | 601-23-36-5480-318 |
| 154583 | 3 | Invoice | CABLE FOR COUNCIL TV's | 07/16/2021 | 25.80 | 01/22 | 602-23-36-5480-318 |
| 154583 | 4 | Invoice | CABLE FOR COUNCIL TV's | 07/16/2021 | 25.80 | 01/22 | 603-23-36-5480-318 |
| Total 154583: | | | | | 128.99 | | |
| 154627 | 1 | Invoice | BATTERIES FOR LOCATOR | 07/19/2021 | 15.99 | 01/22 | 601-23-52-5588-318 |
| Total 154627: | | | | | 15.99 | | |
| 154797 | 1 | Invoice | BUILDING SUPPLIES | 07/26/2021 | 10.49 | 02/22 | 100-24-36-5480-318 |
| 154797 | 2 | Invoice | BUILDING SUPPLIES | 07/26/2021 | 7.49 | 02/22 | 601-23-36-5480-318 |
| 154797 | 3 | Invoice | BUILDING SUPPLIES | 07/26/2021 | 6.00 | 02/22 | 602-23-36-5480-318 |
| 154797 | 4 | Invoice | BUILDING SUPPLIES | 07/26/2021 | 5.99 | 02/22 | 603-23-36-5480-318 |
| Total 154797: | | | | | 29.97 | | |
| Total WEBSTER CITY TRUE VALUE (2155): | | | | | 179.84 | | |

| Invoice | Seq | Type | Description | Invoice Date | Total Cost | Period | GL Account |
|--|-----|---------|----------------------------------|--------------|------------|--------|--------------------|
| WOLFGRAM, JOE (5604) | | | | | | | |
| 070721 | 1 | Invoice | LED LIGHTING REBATE/1204 BANK | 07/07/2021 | 137.94 | 02/22 | 601-23-36-5930-979 |
| 070721 | 2 | Invoice | CB LED LIGHTING REBATE/1204 BANK | 07/07/2021 | 64.35 | 02/22 | 601-23-53-5930-979 |
| Total 070721: | | | | | 202.29 | | |
| Total WOLFGRAM, JOE (5604): | | | | | 202.29 | | |
| WOOLSTOCK MUTUAL TELEPHONE ASN (1054) | | | | | | | |
| 839-1086 08/ | 1 | Invoice | INTERNET SERVICE | 08/01/2021 | 3.03 | 02/22 | 100-24-14-5435-230 |
| 839-1086 08/ | 2 | Invoice | INTERNET SERVICE | 08/01/2021 | 21.90 | 02/22 | 601-23-80-5903-230 |
| 839-1086 08/ | 3 | Invoice | INTERNET SERVICE | 08/01/2021 | 6.74 | 02/22 | 602-23-80-5921-230 |
| 839-1086 08/ | 4 | Invoice | INTERNET SERVICE | 08/01/2021 | 2.02 | 02/22 | 603-23-80-5921-230 |
| 839-1086 08/ | 5 | Invoice | INTERNET SERVICE | 08/01/2021 | 3.61 | 02/22 | 100-24-12-5430-230 |
| 839-1086 08/ | 6 | Invoice | INTERNET SERVICE | 08/01/2021 | 12.03 | 02/22 | 601-23-81-5921-230 |
| 839-1086 08/ | 7 | Invoice | INTERNET SERVICE | 08/01/2021 | 7.22 | 02/22 | 602-23-81-5921-230 |
| 839-1086 08/ | 8 | Invoice | INTERNET SERVICE | 08/01/2021 | 1.20 | 02/22 | 603-23-81-5921-230 |
| 839-1086 08/ | 9 | Invoice | INTERNET SERVICE | 08/01/2021 | 6.02 | 02/22 | 100-24-30-5380-230 |
| 839-1086 08/ | 10 | Invoice | INTERNET SERVICE | 08/01/2021 | 6.02 | 02/22 | 601-24-30-5380-230 |
| 839-1086 08/ | 11 | Invoice | INTERNET SERVICE | 08/01/2021 | 6.02 | 02/22 | 602-24-30-5380-230 |
| 839-1086 08/ | 12 | Invoice | INTERNET SERVICE | 08/01/2021 | 6.01 | 02/22 | 603-24-30-5380-230 |
| 839-1086 08/ | 13 | Invoice | INTERNET SERVICE | 08/01/2021 | 14.44 | 02/22 | 100-21-22-5140-230 |
| 839-1086 08/ | 14 | Invoice | INTERNET SERVICE | 08/01/2021 | 38.50 | 02/22 | 100-21-21-5110-230 |
| 839-1086 08/ | 15 | Invoice | INTERNET SERVICE | 08/01/2021 | 7.22 | 02/22 | 601-23-52-5588-230 |
| 839-1086 08/ | 16 | Invoice | INTERNET SERVICE | 08/01/2021 | 7.22 | 02/22 | 601-23-51-5566-230 |
| 839-1086 08/ | 17 | Invoice | INTERNET SERVICE | 08/01/2021 | 14.44 | 02/22 | 602-23-61-5642-230 |
| 839-1086 08/ | 18 | Invoice | INTERNET SERVICE | 08/01/2021 | 4.81 | 02/22 | 100-23-43-5361-230 |
| 839-1086 08/ | 19 | Invoice | INTERNET SERVICE | 08/01/2021 | 19.25 | 02/22 | 100-22-42-5233-230 |
| 839-1086 08/ | 20 | Invoice | INTERNET SERVICE | 08/01/2021 | 118.62 | 02/22 | 601-24-16-5921-230 |
| 839-1086 08/ | 21 | Invoice | INTERNET SERVICE | 08/01/2021 | 20.84 | 02/22 | 602-24-16-5921-230 |
| 839-1086 08/ | 22 | Invoice | INTERNET SERVICE | 08/01/2021 | 20.84 | 02/22 | 603-24-16-5921-230 |
| Total 839-1086 08/01/21: | | | | | 348.00 | | |
| 839-3034 08/ | 1 | Invoice | INTERNET SERVICE/RSVP | 08/01/2021 | 29.95 | 02/22 | 100-22-42-5280-230 |
| Total 839-3034 08/01/21: | | | | | 29.95 | | |
| 839-6192 08/ | 1 | Invoice | INTERNET SERVICE/DEPOT | 08/01/2021 | 29.95 | 02/22 | 100-22-42-5221-230 |
| Total 839-6192 08/01/21: | | | | | 29.95 | | |
| 839-7981 08/ | 1 | Invoice | INTERNET SERVICE/FULLER HALL | 08/01/2021 | 29.95 | 02/22 | 100-22-42-5233-210 |
| Total 839-7981 08/01/21: | | | | | 29.95 | | |
| Total WOOLSTOCK MUTUAL TELEPHONE ASN (1054): | | | | | 437.85 | | |
| ZIEGLER, INC. (1071) | | | | | | | |
| IN000177109 | 1 | Invoice | CLIP TRIM | 07/16/2021 | 1.98 | 01/22 | 204-23-30-5310-314 |
| Total IN000177109: | | | | | 1.98 | | |
| IN000179221 | 1 | Invoice | GASKET & BASE | 07/18/2021 | 201.68 | 01/22 | 204-23-30-5310-314 |
| Total IN000179221: | | | | | 201.68 | | |

| Invoice | Seq | Type | Description | Invoice Date | Total Cost | Period | GL Account |
|-----------------------------|-----|------|-------------|--------------|------------|--------|------------|
| Total ZIEGLER, INC. (1071): | | | | | 203.66 | | |
| Total 08/02/2021: | | | | | 222,438.60 | | |
| Grand Totals: | | | | | 223,925.28 | | |

Report GL Period Summary

| GL Period | Amount |
|---------------|------------|
| 02/22 | 117,235.17 |
| 01/22 | 32,332.17 |
| 12/21 | 74,357.94 |
| Grand Totals: | 223,925.28 |

Vendor number hash: 594426
 Vendor number hash - split: 1085076
 Total number of invoices: 179
 Total number of transactions: 356

| Terms Description | Invoice Amount | Net Invoice Amount |
|-------------------|----------------|--------------------|
| Open Terms | 223,925.28 | 223,925.28 |
| Grand Totals: | 223,925.28 | 223,925.28 |

FUND LIST TOTALS FOR BILLS AUGUST 2, 2021

| <u>Account</u> | <u>Fund</u> | <u>Total Amount</u> |
|-----------------------|---------------------------------|----------------------------|
| 100 | General | 55,561.37 |
| 204 | Road Use Tax Funds | 7,403.88 |
| 205 | Airport Fund | 4,157.11 |
| 260 | SSMID | 65.00 |
| 300 | Debt Service | 9,154.30 |
| 430 | RAGBRAI | 437.68 |
| 525 | Street Improvement | 17,463.56 |
| 534 | Wilson Brewer Park Impr Project | 14,925.00 |
| 601 | Electric Utility | 27,822.40 |
| 602 | Water Utility | 29,493.73 |
| 603 | Sewer Fund | 53,005.21 |
| 902 | Medical/Flex | 4,436.04 |
| | Grand Total | 223,925.28 |



MEMORANDUM

TO: Mayor and Council
FROM: Ken Wetzler, Public Works Director
DATE: July 24, 2021
RE: 2021 HMA Street Improvement Project

SUMMARY: The 2021 HMA Improvement Project was sent out for bids. The project will consist of new asphalt street pavement, water main, and parking lot repairs as listed below.

PREVIOUS COUNCIL ACTION: Council authorized the construction of the 2021 Second Street Reconstruction Project in the CIP.

BACKGROUND/DISCUSSION: The 2021 HMA Street Improvement Project will include the following:

1. Betsy Lane from Beach Street to Sunset Drive;
2. Seneca Street from Pleasant Street to Bank Street;
3. Parking Lot Reconstruction at 718 First Street, also known as the “Freeman Journal Parking Lot”;
4. Betsy Lane Water Main Replacement; and,
5. Parking Lot Reconstruction at the 400 block of 1st, also known as the “City Hall Parking Lot”.

The scheduled completion date is August 15, 2022

The bid letting was held July 22, 2021 at 3p.m. in City Hall.

The Engineers opinion of probable cost was \$1,281,600.00

Snyder & Associates Engineering has recommended that City award the contract to Heartland Asphalt, Inc., Mason City, Iowa in the total amount of \$882,202.83 with alternate. Note attached engineer letter of recommendation.

| <u>Name and City, State of Contractor</u> | <u>Amount of Bid</u> |
|---|----------------------|
| Heartland Asphalt Inc. Mason City, Iowa | \$876,791.33 |
| Plus, Alternate | <u>\$5,411.50</u> |
| Total | \$882,202 .83 |

FINANCIAL IMPLICATIONS: Funding for the project is from LOSST and general obligation bonds. The opinion of probable cost for both the construction and the materials is as follows (includes construction, engineering, construction observation, and contingency):

| | |
|---|----------------------|
| BASE BID | |
| Subtotal Construction Cost | \$1,118,800.00 |
| Engineering, Construction, and Administration | <u>\$ 162,800.00</u> |
| Total Project Cost | \$1,281,600.00 |

RECOMMENDATION: The 2021 Street Improvement Project be competed as described in the plans and specification and award the contract to Heartland Asphalt Inc., 2601 South Federal Ave., Mason City, Iowa 50401 in the amount of \$882,202.83

ALTERNATIVES: The City Council could choose to delay the project, or direct to remove any part of the project.

July 23, 2021

Matt Alcazar
City of Webster City
400 East Second Street
Webster City, Iowa 50595

RE: 2021 HMA STREET IMPROVEMENT PROJECT
BID LETTING RESULTS AND RECOMMENDATION FOR ACCEPTANCE

Dear Matt:

The bid letting for the 2021 HMA Street Improvement Project was held Thursday, July 22, 2021 with a bid submitted from Heartland Asphalt, Inc. for a Base Bid of \$876,791.33 and Alternate Bid Items totaling \$5,411.50. The engineer's expected cost was a Base Bid of \$1,050,801 and with Alternates at \$7,505. All bid forms were checked and complete.

Heartland Asphalt, Inc. submitted the required 10% bid bond on a sealed project Bid Bond forms through Merchants Bonding Company (Mutual). Heartland Asphalt, Inc is based in Mason City, has the equipment and the employees, and listed capable subcontractors to complete all required improvements. Also, most recently Heartland Asphalt successfully completed the Webster City 2019 Street Improvements Project.

Since the bid received was well below our cost opinion by a competent contractor, Snyder & Associates, Inc. recommends acceptance of the bid provided by Heartland Asphalt, Inc.

If you have any questions please call me at 515-368-0228 or email me at pjacobson@snyder-associates.com. Thank you.

Respectfully,

SNYDER & ASSOCIATES, INC.



Paul D. Jacobson, P.E.

Cc: John Haldeman, P.E.

RESOLUTION NO. 2021 - _____

**FINALLY APPROVING AND CONFIRMING PLANS, SPECIFICATIONS
AND FORM OF CONTRACT AND ESTIMATE OF COST FOR THE
2021 HMA STREET IMPROVEMENT PROJECT**

WHEREAS, this Council has heretofore approved plans, specifications and form of contract for the proposed construction of the 2021 HMA Street Improvement Project, as described in the resolution providing for a notice of hearing on proposed plans and specifications and proposed form of contract for such 2021 HMA Street Improvement Project and the taking of bids therefor; and

WHEREAS, hearing has been held on objections to the proposed plans, specifications, and form of contract and to the cost of the 2021 HMA Street Improvement Project, and no objections were provided.

NOW THEREFORE IT IS RESOLVED by the Council of Webster City, Iowa, as follows:

That the plans, specifications and form of contract, and estimate of cost referred to in the preamble hereof be and the same are hereby finally approved and the prior action of the Council approving them is hereby finally confirmed, and the aforementioned public improvement to be constructed in accordance with the plans, specifications and form of contract is necessary and desirable.

Passed and adopted this 2nd day of August, 2021.

John Hawkins, Mayor

ATTEST: _____
Karyl K. Bonjour, City Clerk

RESOLUTION NO. 2021 - _____

**AWARDING CONTRACT FOR THE
2021 HMA STREET IMPROVEMENT PROJECT**

WHEREAS, pursuant to notice duly published in the manner and form prescribed by resolution of this Council and as required by law, bids and proposals were received by this Council for the 2021 HMA Street Improvement Project: and,

WHEREAS, all of the said bids and proposals have been carefully considered, and it is necessary and advisable that provision be made for the award of the contract for the project.

NOW, THEREFORE, IT IS RESOLVED by the City Council of the City of Webster City, Iowa, as follows:

SECTION 1. The bid for the project submitted by the following contractor is fully responsive to the plans and specifications for the project, heretofore approved by the Council, and is the lowest responsible bid received, such bid being as follows:

| <u>NAME AND ADDRESS OF CONTRACTOR</u> | <u>AMOUNT OF BID</u> |
|---|----------------------|
| Heartland Asphalt Inc., 2601 South Federal Ave., Mason City, Iowa | \$876,791.33 |
| Plus, Alternate | <u>\$5,411.50</u> |
| For a Total of | \$882,202.83 |

SECTION 2. The contract for the Project be and the same is hereby awarded to such contractor at the total estimated cost set out above, the final settlement to be made on the basis of the unit prices therein set out and the actual final quantities of each class of materials furnished, the said contract to be subject to the terms of the aforementioned resolution, the notice of hearing and letting, the plans and specifications and the terms of the bidder's written proposal.

SECTION 3. The Mayor and City Clerk are hereby authorized and directed to enter into a written contract with said contractor for the project.

SECTION 4. The amount of the contractor's performance and/or payment bonds is hereby fixed and determined to be 100% of the amount of the contract.

BE IT FURTHER RESOLVED that said agreement is hereby approved upon being executed by both parties.

Passed and adopted this 2nd day of August, 2021.

John Hawkins, Mayor

ATTEST:

Karyl K. Bonjour, City Clerk



MEMORANDUM

TO: Mayor and City Council
FROM: Planning Director
DATE: July 23, 2021
RE: Public Hearing for Zoning Ordinance Revisions

SUMMARY: The City Council needs to hold a Public Hearing for zoning ordinance revisions recommended by the Planning and Zoning Commission at their July 12, 2021, meeting.

PREVIOUS COUNCIL ACTION: On July 19, 2021, the City Council set the public hearing for August 2, 2021 at 6:05 p.m.

BACKGROUND/DISCUSSION: There were two requests made to the Planning Department:

- 1) The Paw Print Pad, LLC, located on Aldrich Drive, would like to purchase a parcel on Commerce Drive (North half of Lot 5, SE Development Park #2) to relocate their business as a developer has offered to purchase their current property. They would be going from the C-3 District to a M-1 District which does not currently allow a kennel for boarding, daycare, and grooming of dogs. I have researched many other communities, large and small, and the majority allow for such a use in a M-1 District within established guidelines.
- 2) I have received a request from Mike Henely, Webster City, to lease a portion of property owned by the City on the west side of White Fox Road, immediately north of the railroad tracks. See attached plat map. This parcel is in the M-1 (Light Industrial) District and would be used for an outdoor radio-controlled car race track. This is currently not an allowable use. The two lots of interest would measure approximately 100'x100'. This would be enough land for a small track and parking lot. It would be available for all the kids to use.

The P&Z did recommend that the zoning ordinance be amended to add a definition for “kennel” as well as including it as an allowable use in an M-1 (Light Industrial) District. They also recommended allowing an “outdoor race track for radio-controlled vehicles of 1:25 scale or smaller” on the City-owned lot if the City desires to lease the property for that use. Both Justis Burgin, from Paw Print Pad, and Mike Henely, with the race track, will be in attendance to answer any of your questions.

The P&Z also decided to recommend that Chapter 50-116 (40) be revised from:

(40) The following uses permitted in a C-3 (Highway Business) District are allowed in an M-1 (Light Industrial) District: lumber yards, essential service buildings, farm machinery sales, nursery, auto sales, bowling alley, fraternal lodge, and eating and drinking establishments.

to this:

(40) The following uses permitted in a C-3 (Highway Business) District are allowed in an M-1 (Light Industrial) District: lumber yards, essential service buildings, farm machinery sales, auto sales, and eating and drinking establishments.

This was simple housekeeping done to remove uses that no longer exist but had been included at the time zoning changed *years ago* because the uses were already there. Nurseries, bowling alleys, and fraternal lodges are more compatible in the commercial districts.

FINANCIAL IMPLICATIONS: N/A

RECOMMENDATION: Approve the first reading of the ordinance on amending the zoning ordinance, Chapter 50, pertaining to the uses allowed in an M-1 (Light Industrial) District.

ALTERNATIVES: The Council could decide to not approve these amendments with justification.

ORDINANCE NO. 2021 – ____

**AN ORDINANCE AMENDING THE CODE OF ORDINANCES
OF THE CITY OF WEBSTER CITY, IOWA, 1996, BY
AMENDING CHAPTER 50, PERTAINING TO ZONING,
AS IT RELATES TO USES PERMITTED IN THE
M-1 (LIGHT INDUSTRIAL) DISTRICT.**

BE IT ENACTED by the City Council of the City of Webster City, Iowa, as follows, to-wit:

SECTION 1. NEW SECTION. Chapter 50, Section 1, of the Code of Ordinances of the City of Webster City, Iowa, is hereby amended by adding the following definition:

Sec. 50-1. Definitions.

Kennel means any lot, building, structure or premises whereupon or wherein four or more cats and/or dogs over 2 months of age are kept or maintained for any purpose, including boarding, daycare, and grooming for a consideration. Private or commercial kennels as a principal use shall meet all of the following requirements:

- a) No dog having a disease harmful to humans shall be boarded or maintained in the facility.
- b) Methods shall be used to reduce off-site noise which may include the use of sound barrier material or other approved insulation.
- c) Adequate dog runs, either interior or exterior, must be provided for proper care and maintenance of the dogs. Exterior dog runs shall be at least 200' from any "R" District and shall not be used between the hours of 8:00 p.m. and 8:00 a.m.
- d) The kennel shall have flushing drains which shall be connected to an approved sanitary facility, or another approved method, and other physical elements to properly dispose of cleaning and animal waste.

- e) The kennel shall be air-conditioned and heated so that any windows, doors or other openings can be closed at times, except for ingress and egress into the building.
- f) All State of Iowa regulations must be satisfied per Iowa State Code Chapter 162.

SECTION 2. SECTION MODIFIED. Chapter 50, Section 116, number 40, of the Code of Ordinances of the City of Webster City, Iowa, is hereby repealed and the following adopted in lieu thereof:

Sec. 50-116. M-1 (Light Industrial) District.

(40) The following uses permitted in a C-3 (Highway Business) District are allowed in an M-1 (Light Industrial) District: lumber yards, essential service buildings, farm machinery sales, auto sales, and eating and drinking establishments.

SECTION 3. NEW SECTION. Chapter 50, Section 116, of the Code of Ordinances of the City of Webster City, Iowa, is hereby amended by adding the following allowable uses in an M-1 (Light Industrial) District, numbered 41 & 42:

Sec. 50-116. M-1 (Light Industrial) District.

- (41) Kennel.
- (42) Outdoor race track for radio-controlled vehicles of 1:25 scale or smaller.

SECTION 4. REPEALER. All ordinances or parts of ordinances in conflict with the provisions of this ordinance are hereby repealed.

SECTION 5. SEVERABILITY CLAUSE. If any section, provision or part of this ordinance shall be adjudged invalid or unconstitutional, such adjudication shall not affect the validity of the ordinance as a whole or any section, provision, or part thereof not adjudged invalid or unconstitutional.

SECTION 6. WHEN EFFECTIVE. This ordinance shall be in effect from and after its final passage, approval and publication as provided by law.

Passed and adopted this _____ day of _____, 2021.

CITY OF WEBSTER CITY, IOWA

(seal)

John Hawkins, Mayor

ATTEST:

Karyl K. Bonjour, City Clerk

White Fox Road

Legend

 White Fox Rd

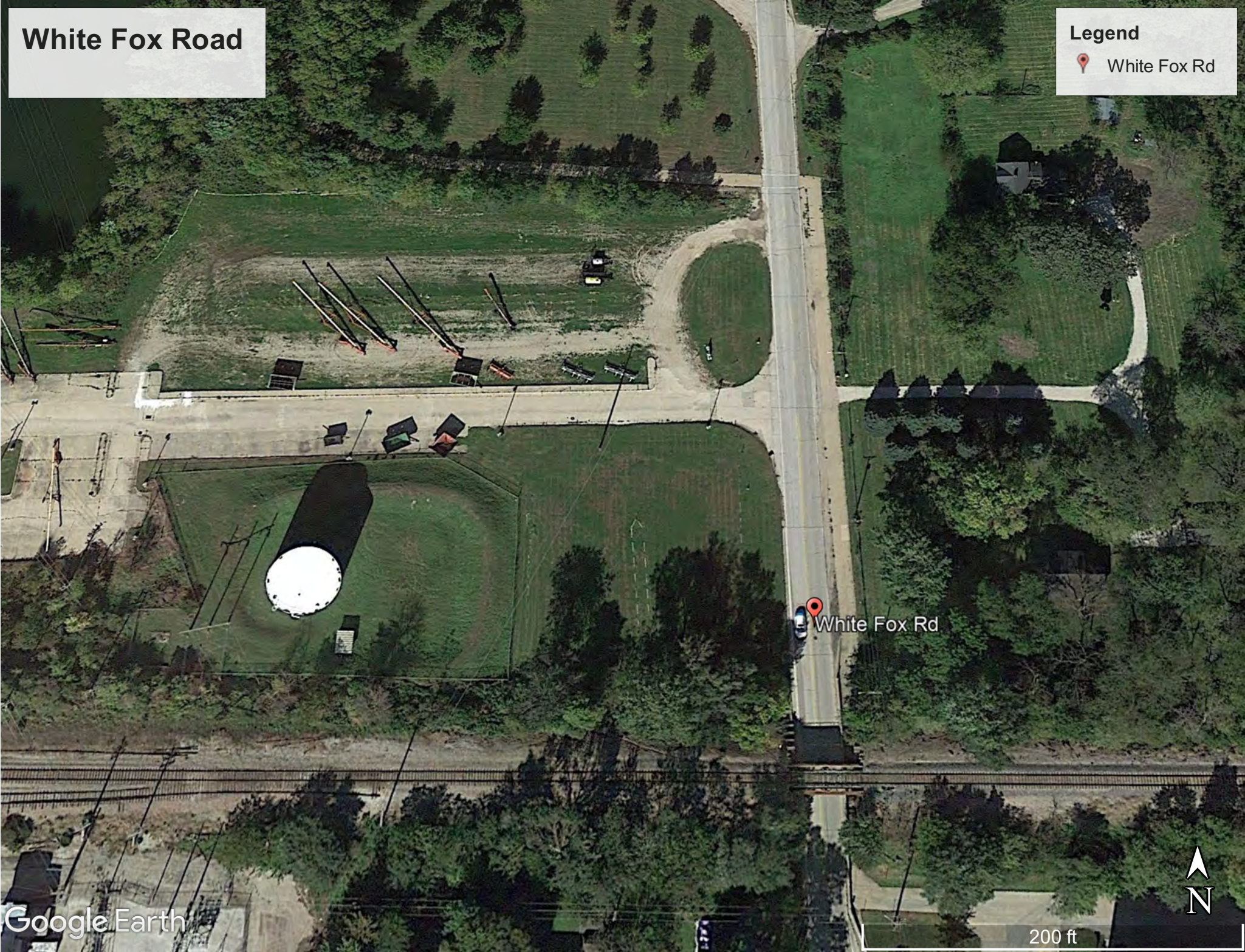

ORDINANCE NO. 2021 –

AN ORDINANCE AMENDING THE CODE OF ORDINANCES OF THE CITY OF WEBSTER CITY, IOWA, 2019, BY AMENDING ARTICLE III TO CHAPTER 20 PERTAINING TO HOTEL/MOTEL TAX BOARD IN THE CITY OF WEBSTER CITY, IOWA.

BE IT ENACTED BY THE CITY COUNCIL OF THE CITY OF WEBSTER CITY, IOWA, AS FOLLOWS TO WIT:

SECTION 1. SECTION MODIFIED. The following Section of Chapter 20: Hotel/Motel Tax of the Code of Ordinances of the City of Webster City, Iowa, 2019, is hereby repealed in part and the following adopted in lieu thereof:

Sec. 20-65- Hotel/motel tax board.

The board appointed by the city council shall have five members comprised of one member from city government, one member from the business community, and three members from the public at-large. The term of office of the members of the board shall be for four years and shall commence on June 1 of their respective term. The board will give the city council a proposal each year showing the anticipated revenues, projected uses and desired outcomes along with a report on the use and results of previous year's investments.

(Code 1996, §§ 171.06, 171.07)

Sec. 20-66. – Disbursement of funds.

As part of the promotion and development of recreational, entertainment and cultural attractions, events and facilities in the city, the first twenty-five percent (25%) of each year's revenue collected by the city shall be designated for Park and Recreation capital projects and improvements within the City of Webster City, Iowa.

After the above-noted percentage is allocated for Park and Recreation needs, out of the remaining year's revenue collected, twenty-seven thousand dollars (\$27,000.00) of said remaining revenue shall be designated for the Webster City Area Chamber of Commerce for their use in the promotion and development of recreational, entertainment and cultural attractions, events and facilities in the city. As part of receiving said funds, the Webster City Area Chamber of Commerce shall provide the city council with an annual report on the use of said funds prior to the distribution of the next years funds.

The city council shall have the final authority on the disbursement of remaining funds from the recommendations of a board appointed by the city council.

SECTION 2. REPEALER. All ordinances or parts of ordinances in conflict with the provisions of this ordinance are hereby repealed.

SECTION 3. SEVERABILITY CLAUSE. If any section, provision or part of this ordinance shall be adjudged invalid or unconstitutional, such adjudication shall not affect the validity of the ordinance as a whole or any section, provision, or part thereof not adjudged invalid or unconstitutional.

SECTION 4. WHEN EFFECTIVE. This ordinance shall be effective upon final passage, approval, and publication.

Passed and adopted this _____ day of _____, 2021.

John Hawkins, Mayor

ATTEST:

Karyl K. Bonjour, City Clerk



MEMORANDUM

TO: Mayor and City Council

FROM: Ken Wetzler, Public Works Director

DATE: July 23, 2021

RE: Change Order No. 5- 2020 713 2nd Street Façade, Webster City

SUMMARY: A change order is requested from Westbrooke Construction, Urbandale, Iowa, for the 713 2nd Street Façade project to address the changes in the scope of work listed in the background/discussion below.

PREVIOUS COUNCIL ACTION: Council approved Change Order No. 4 for the project to Westbrooke Construction, Urbandale, Iowa on January 18th, 2021

BACKGROUND/DISCUSSION: Change order work includes;
RFP #11

Reinforce existing roof structure to provide structural capacity for roof loads as indicated on attached drawings A101 and A201, including:

- A. Add W-shape steel beams above existing roof with end frames and hangar rods down to existing wood girder trusses to reinforce existing wood girder trusses. Hangar rods to be at mid-point of wood truss girder with new supplemental blocking and at 1/3 points of wood truss girder at existing blocking points. Provide HSS 4x4 frame supports at east and west ends of wood truss girder/supplemental W-shape. Refer to attached drawings. Exterior steel to be hot dipped galvanized.
- B. Demo existing tin ceiling as required for installation of end frames and for connection of new hangar rods to existing wood girder trusses as required. Provide care when removing historic tile to prevent damage. Salvage any demo material to Owner.
- C. Provide new beam pocket in existing masonry parapet wall with new cmu bond beam over existing wood girder as indicated on drawings. Beam pocket and condition of existing masonry to be reviewed/verified with Structural Engineer upon demolition.
- D. Flash beam pockets and hangar rods thru existing EPDM membrane roof to maintain water tight enclosure and existing roof drainage under new supplemental steel beams. e. Owner will provide temporary jack column at existing girder truss to adjust in increments to try and take out deflection in existing wood girder truss as possible. Hangar rods to be tightened incrementally as any deflection is removed.

By virtue of such changes in the Contract, the following revisions shall be made in the Contract price:

| | |
|---|---------------------|
| Original contract with Westbrooke Construction, Urbandale, Iowa | \$530,950.00 |
| Change Order No. 1 | \$ 14,160.00 |
| Change Order No. 2 | \$ 14,985.00 |
| Change Order No. 3 | \$ 2,550.00 |
| Change Order No. 4 | \$ 5,945.00 |
| Change Order No. 5 requested amount | <u>\$134,370.00</u> |
| Revised Contract price | \$702,960.00 |

FINANCIAL IMPLICATIONS: Funding for the project is from the City's CDBG Fund.

RECOMMENDATION: Approve Change Order No.5 in the amount of \$134,370.00 per the attached resolution for the revised contract price of \$702,960.00

ALTERNATIVES: The City Council could choose to not approve Change Order No.5.

PUBLIC WORKS DIRECTOR COMMENTS: Recommend approval of Change Order No. 5 to Westbrooke Construction, Urbandale, Iowa in the amount of \$134,370.00

RESOLUTION NO. 2021 -

**APPROVING CHANGE ORDER NO. 5 TO THE
2020 713 2nd STREET FAÇADE PROJECT WITH
WESTBROOKE CONSTRUCTION, URBANDALE, IOWA**

WHEREAS, on May 18th, 2020, the City Council of the City of Webster City, Iowa, did enter into a contract with Westbrooke Construction, Urbandale, Iowa, for completion of the 2020 713 2nd Street Façade Project,

WHEREAS, Contract Change Order No. 5 has been prepared as follows:

Reason for change:

RFP #11 – Reinforce existing roof structure to provide structural for roof loads. - \$134,370.00

By virtue of such changes in the Contract, the following revisions shall be made in the Contract price:

| | | |
|-------------------------------|-----------|-------------------|
| Original Contract Price | \$ | 530,950.00 |
| Change Order No. 1 | \$ | 14,160.00 |
| Change Order No. 2 | \$ | 14,985.00 |
| Change Order No. 3 | \$ | 2,550.00 |
| Change Order No. 4 | \$ | 5,945.00 |
| Change Order No. 5 | \$ | <u>134,370.00</u> |
| Revised Contract Price | \$ | 702,960.00 |

NOW THEREFORE BE IT RESOLVED by the City Council of the City of Webster City, Iowa, that Change Order No. 5 to the 2020 713 2nd Street Façade Project Contract with Westbrooke Construction, Urbandale, Iowa, as described above and attached hereto is hereby approved.

Passed and adopted this 2nd day of August 2021.

John Hawkins, Mayor

ATTEST: _____
Karyl K. Bonjour, City Clerk



AIA[®]

Document G701™ – 2017

Change Order

| | | |
|---|--|---|
| PROJECT: <i>(Name and address)</i> Facade Renovation 713 2nd Street Webster City | CONTRACT INFORMATION: Contract For: General Construction Date: May 18, 2020 | CHANGE ORDER INFORMATION: Change Order Number: 005 Date: July 22, 2021 |
| OWNER: <i>(Name and address)</i> City of Webster City 400 2nd St, Webster City, Iowa | ARCHITECT: <i>(Name and address)</i> ASK Studio 3716 Ingersoll Ave. Ste A, Des Moines Iowa 50312 | CONTRACTOR: <i>(Name and address)</i> Westbrooke Construction 7207 Douglas Ave., Urbandale, Iowa |

THE CONTRACT IS CHANGED AS FOLLOWS:

(Insert a detailed description of the change and, if applicable, attach or reference specific exhibits. Also include agreed upon adjustments attributable to executed Construction Change Directives.)

Add \$134,370.00; RFP 11, supplemental roof structure framing with beam pockets.

| | |
|--|---------------|
| The original Contract Sum was | \$ 530,950.00 |
| The net change by previously authorized Change Orders | \$ 37,640.00 |
| The Contract Sum prior to this Change Order was | \$ 568,590.00 |
| The Contract Sum will be increased by this Change Order in the amount of | \$ 134,370.00 |
| The new Contract Sum including this Change Order will be | \$ 702,960.00 |

The Contract Time will be increased by Two Hundred Fifty One (251) days.
The new date of Substantial Completion will be Nov. 1, 2021

NOTE: This Change Order does not include adjustments to the Contract Sum or Guaranteed Maximum Price, or the Contract Time, that have been authorized by Construction Change Directive until the cost and time have been agreed upon by both the Owner and Contractor, in which case a Change Order is executed to supersede the Construction Change Directive.

NOT VALID UNTIL SIGNED BY THE ARCHITECT, CONTRACTOR AND OWNER.

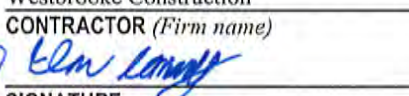
| | | |
|---|--|---|
| ASK Studio ARCHITECT <i>(Firm name)</i> | Westbrooke Construction CONTRACTOR <i>(Firm name)</i> | City of Webster City OWNER <i>(Firm name)</i> |
|  SIGNATURE |  SIGNATURE | SIGNATURE |
| Michael Kastner, Principal PRINTED NAME AND TITLE | Ian Conway PRINTED NAME AND TITLE | PRINTED NAME AND TITLE |
| 7.23.2021 DATE | 7.23.21 DATE | DATE |



Micheal Kastner
ASK Studio

7-19-21

Re: 712 2nd Street Webster City, Roof structural repairs budget REVISED 7-19-21

Per drawings with the following notes per our discussion.

Delete all interior steel columns.

Remove tin ceiling only as needed at each centerline for all thread and steel plates.

Masonry

Demo parapet as necessary to top of each wood truss.

Add bond beam and steel plate at each location for setting steel beam.

Process to be done in the following manner.

Beam pockets 1 and 4, both sides completed together.

Beam pockets 2 and 5 both sides completed together.

Beam pocket 3 and 6 both sides completed together.

This scope of work is \$134,370.00

This reflects price increases on the steel. Please note that suppliers are only holding prices for 14 days.



ARCHITECTS SCHIPPER KASTNER

REQUEST FOR PROPOSAL

ARCHITECTURE INTERIORS PLANNING

PROJECT NAME: Elks Lodge_713 2nd St_Webster City

PROJECT NUMBER: 19013

RFP NUMBER: **11** DATE: 5.19.2021

The Work shall be carried out in accordance with the following supplemental instructions issued in accordance with the Contract Documents without changes in Contract Sum or Contract Time. Proceeding with the Work in accordance with these instructions indicates your acknowledgement that there will be no changes in the Contract Sum or Contract Time.

Attachments: A101 dated 5.19.2021
A201 dated 5.19.2021

1. Reinforce existing roof structure to provide structural capacity for roof loads as indicated on attached drawings A101 and A201, including:
 - a. Add W-shape steel beams above existing roof with end frames and hangar rods down to existing wood girder trusses to reinforce existing wood girder trusses. Hangar rods to be at mid point of wood truss girder with new supplemental blocking and at 1/3 points of wood truss girder at existing blocking points. Provide HSS 4x4 frame supports at east and west ends of wood truss girder/supplemental W-shape. Refer to attached drawings. Exterior steel to be hot dipped galvanized.
 - b. Demo existing tin ceiling as required for installation of end frames and for connection of new hangar rods to existing wood girder trusses as required. Provide care when removing historic tile to prevent damage. Salvage any demo material to Owner.
 - c. Provide new beam pocket in existing masonry parapet wall with new cmu bond beam over existing wood girder as indicated on drawings. Beam pocket and condition of existing masonry to be reviewed/verified with Structural Engineer upon demolition.
 - d. Flash beam pockets and hangar rods thru existing EPDM membrane roof to maintain water tight enclosure and existing roof drainage under new supplemental steel beams.
 - e. Owner will provide temporary jack column at existing girder truss to adjust in increments to try and take out deflection in existing wood girder truss as possible. Hangar rods to be tightened incrementally as any deflection is removed.

End of RFP

ARCHITECTS SCHIPPER KASTNER
3716 Ingersoll Ave, Ste A, Des Moines, IA 50312
P: 515.277.6707 www.askstudio.com

SCOPE OF WORK:

THE HISTORIC BALLROOM AREA WHICH IS THE SOUTH 3/5TH OF THE 2ND FLOOR IS AN OPEN SPACE WITH NO INTERMEDIATE SUPPORTS. A TIN CEILING AND CORNICE REMAIN OVER THIS BALLROOM AREA. THE EXISTING ROOF STRUCTURE IS COMPRISED OF 6 WOOD GIRDER TRUSSES ORIENTED EAST-WEST AND CLEAR SPANNING FROM EXTERIOR WALL TO EXTERIOR WALL. 2X12 JOISTS, RUNNING NORTH-SOUTH, ARE FRAMED BETWEEN THE GIRDER TRUSSES. AT SOME POINT IN THE PAST A STEEL COLUMN WAS ADDED UNDER THE NORTH GIRDER TRUSS. ALL GIRDER TRUSSES ARE SHOWING MAJOR DEFLECTION.

STRUCTURAL ENGINEERING REPORT HAS INDICATED THAT THE 2X12 N-S JOISTS ARE STRUCTURALLY ADEQUATE, BUT THE GIRDER TRUSSES ARE SEVERELY UNDER CAPACITY FOR THE LOADS BEING CARRIED.

TO PROVIDE SUPPLEMENTAL STRUCTURAL SUPPORT FOR THE EXISTING WOOD GIRDER TRUSSES, A NEW W-SHAPE STEEL BEAM IS TO BE ADDED DIRECTLY ABOVE EACH GIRDER TRUSS. THE NEW STEEL BEAM WILL SET APPROXIMATELY 8" ABOVE THE EXISTING ROOF LINE AND BE SUPPORTED BY NEW BEAM POCKETS IN THE EXISTING BRICK MASONRY PARAPET WALL. A TUBE STEEL SUPPORT BRACKET WILL BE ADDED AT EACH END AT THE INTERIOR FACE OF THE EXISTING BRICK WALL. INTERMEDIATE THREADED SUPPORT RODS, AT MID-POINT AND 1/3 POINTS, WILL BE ADDED BETWEEN THE STEEL BEAM AND GIRDER TRUSS TO PROVIDE SUPPORT. THREADED SUPPORT RODS TO PROVIDE ADJUSTABILITY FOR GIRDER TRUSSES TO BE JACKED UP TO REDUCE DEFLECTION AS POSSIBLE.

NEW STEEL BEAM WILL SET ABOVE EXISTING ROOF AND WILL PROJECT APPROX. 12" ABOVE THE EXISTING WEST PARAPET. THE SOUTH PARAPET ON THE PRIMARY STREET FAÇADE IS TALLER THAN THE EAST AND WEST PARAPET AND WILL HIDE THE NEW BEAMS. THE NORTH FAÇADE DOES NOT HAVE A PARAPET. THE FIRST BEAM/GIRDER SETS APPROX. 16' BACK FROM THE NORTH EDGE OF THE BUILDING.

ON THE INTERIOR THE THREADED SUPPORT RODS AND TUBE STEEL END FRAMES WILL BE ABOVE THE EXISTING CEILING LINE. SECTIONS OF THE EXISTING TIN CEILING PANELS WILL NEED TO BE REMOVED TO PROVIDE ACCESS FOR INSTALLATION OF THE THREADED RODS AND FRAME. CEILING PANELS THAT ARE REMOVED ARE TO BE SALVAGED FOR REUSE/RESTORATION DURING THE PHASE 2 INTERIOR RENOVATIONS. THE EXISTING TEMPORARY SUPPORT COLUMN AT BALLROOM ON SOUTH SIDE TO BE REMOVED UPON INSTALLATION OF SUPPLEMENTAL SUPPORT BEAMS. THE EXISTING STEEL COLUMN AT NORTH TRUSS GIRDER TO REMAIN.

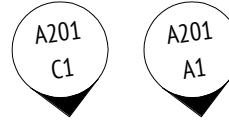

KEYED NOTES

- 1 NEW SUPPLEMENTAL STRUCTURAL SUPPORT FOR EXISTING ROOF GIRDERS. W24X55 STEEL BEAM SET ABOVE EXISTING ROOF. SET INTO BEAM POCKET IN EXISTING PARAPET. REFER TO DETAIL A2/A201.
- 2 EXISTING HISTORIC TIN CEILING AT EXISTING BALLROOM AREA. PANELS TO BE REMOVED AS REQUIRED FOR CONNECTION OF NEW THREADED RODS FROM SUPPORT BEAM TO EXISTING WOOD GIRDER AS INDICATED IN SECTION B2/A102. REMOVED TIN CEILING PANELS TO BE SALVAGED FOR RESTORATION/REUSE IN PHASE 2 INTERIOR RENOVATION.
- 3 EXISTING STEEL COLUMN TO REMAIN.
- 4 EXISTING TEMPORARY SHORING SUPPORT COLUMN/JACK. COLUMN TO BE REMOVED AFTER INSTALLATION OF SUPPLEMENTAL SUPPORT BEAMS.
- 5 EXISTING BRICK.

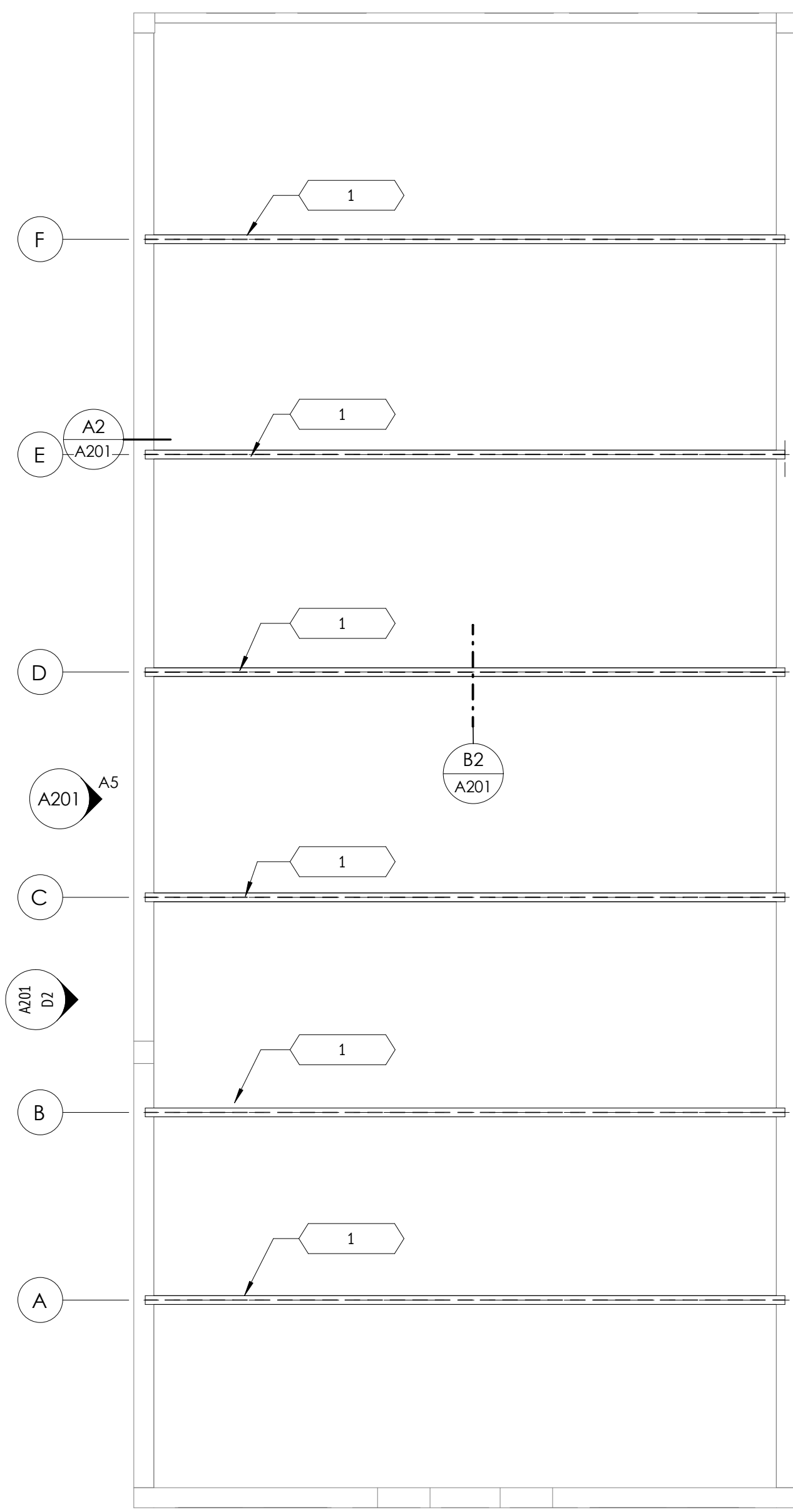

A1 ROOF
SCALE: 1/8" = 1'-0"

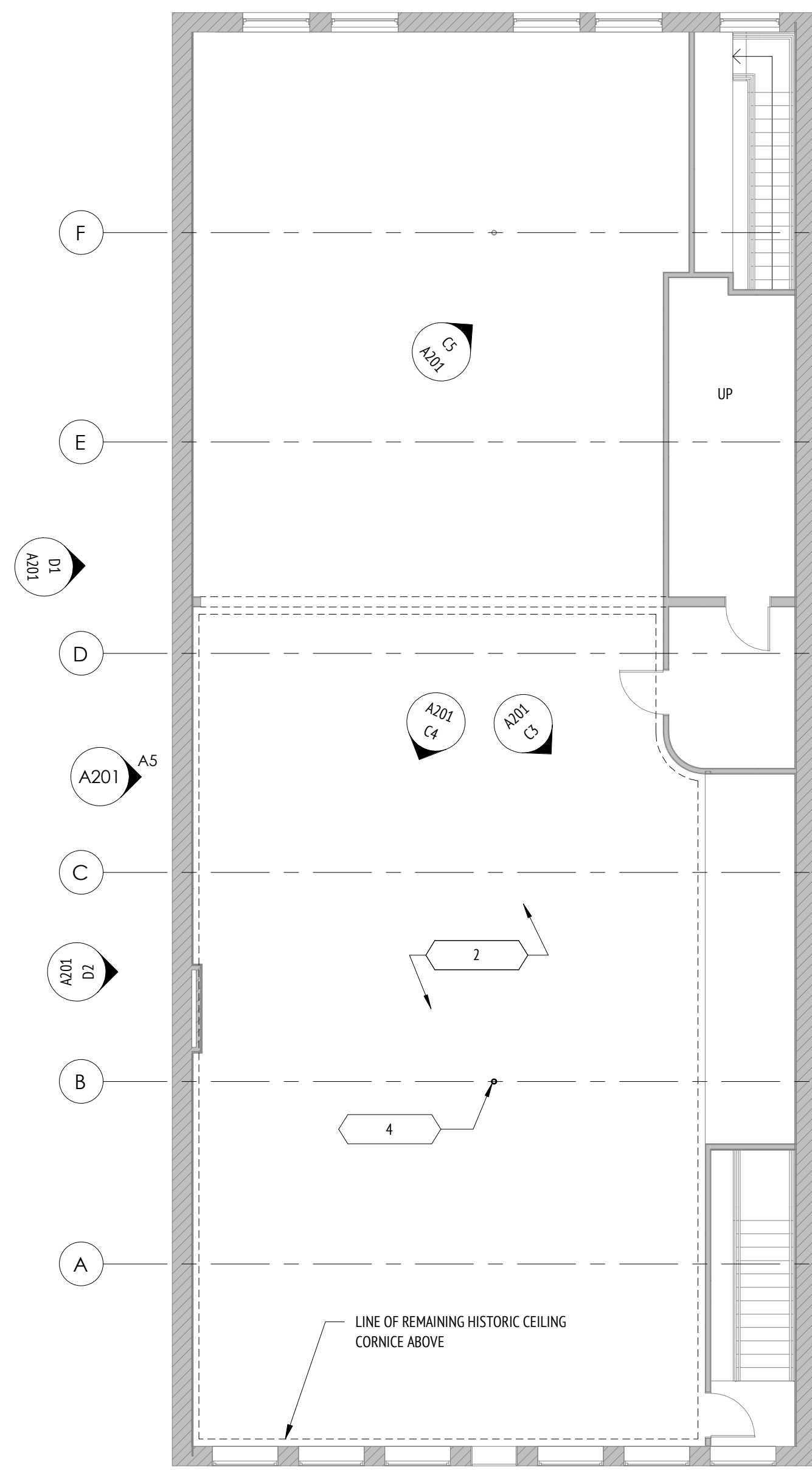

A2 2ND FLOOR
SCALE: 1/8" = 1'-0"

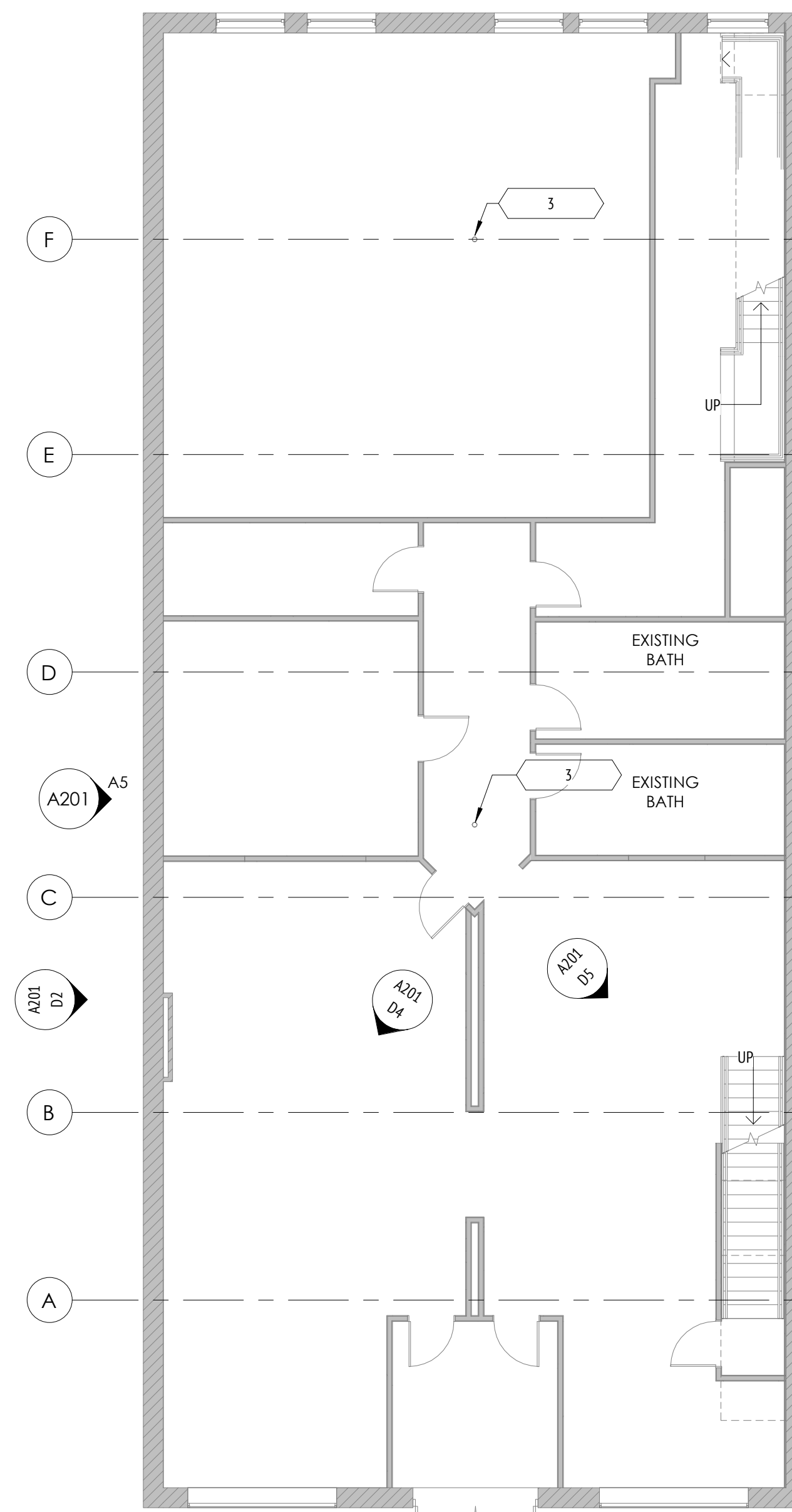

A3 1ST FLOOR
SCALE: 1/8" = 1'-0"

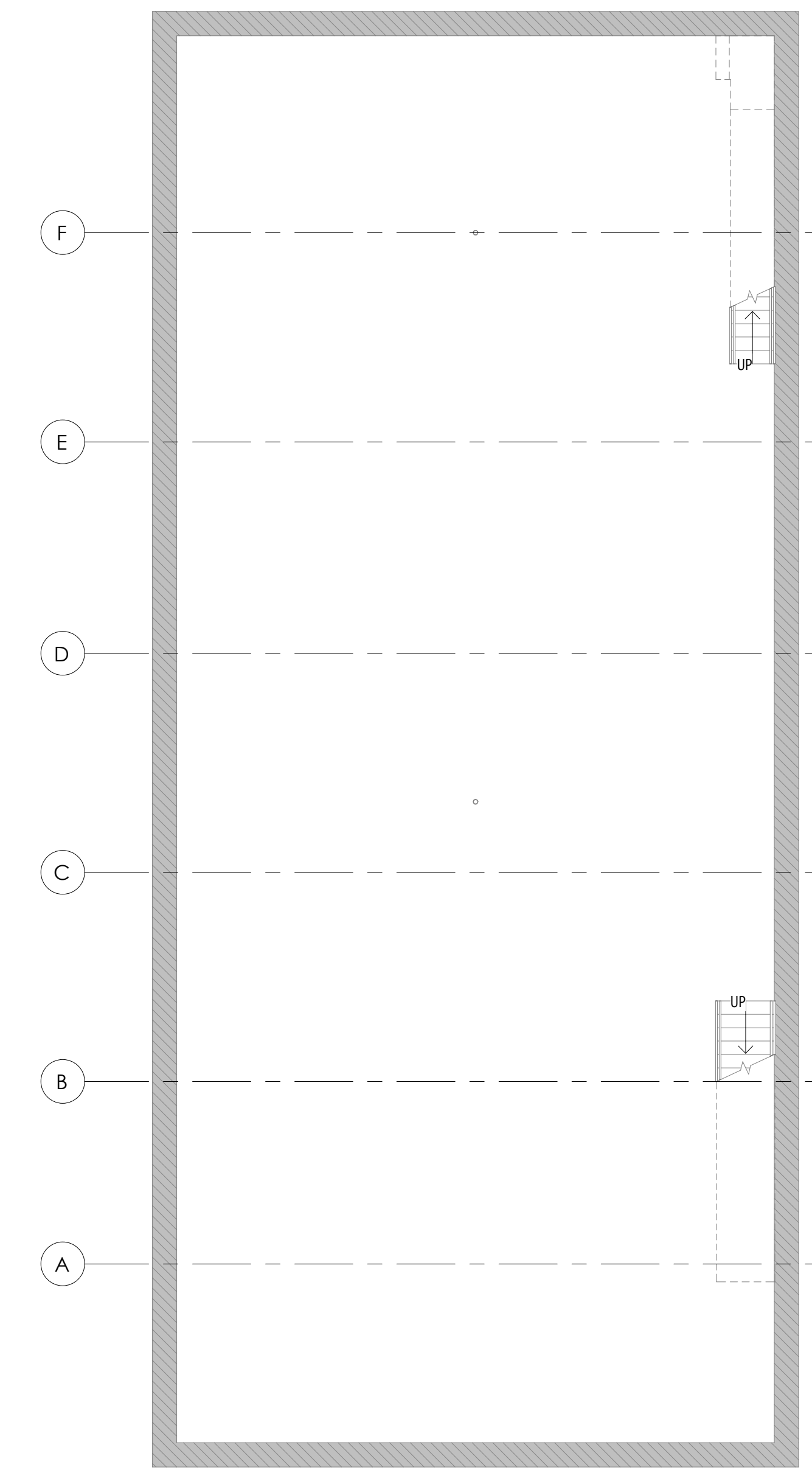

A5 BASEMENT
SCALE: 1/8" = 1'-0"

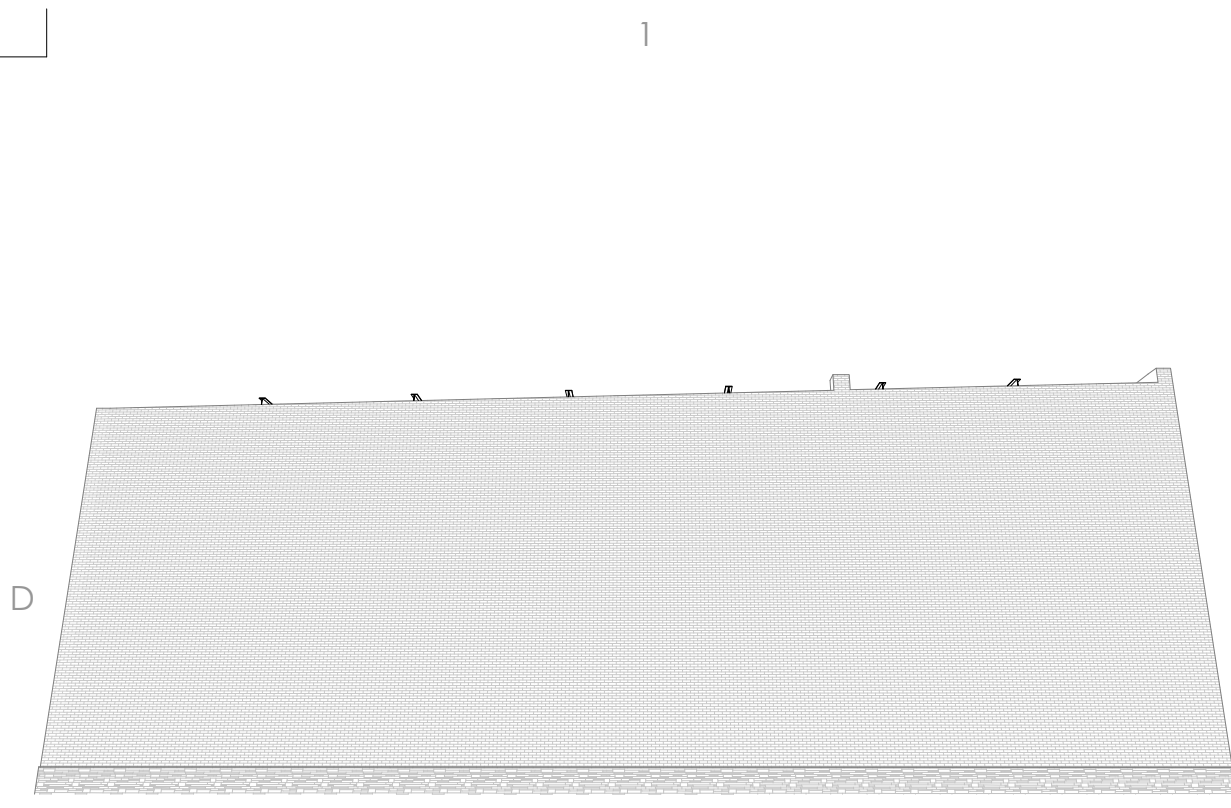

D1 WEST ELEVATION PERSPECTIVE
SCALE: 12" = 1'-0"



D2 NON PRIMARY FACADE VIEW (WEST)
SCALE: 12" = 1'-0"



D3 STREET ELEVATION VIEW
SCALE: 12" = 1'-0"

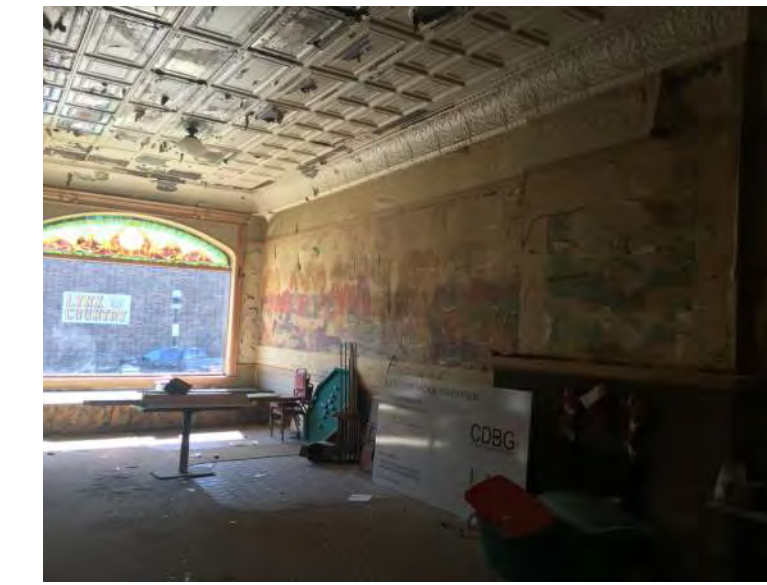

D4 1ST FLOOR AT ENTRY
SCALE: 12" = 1'-0"

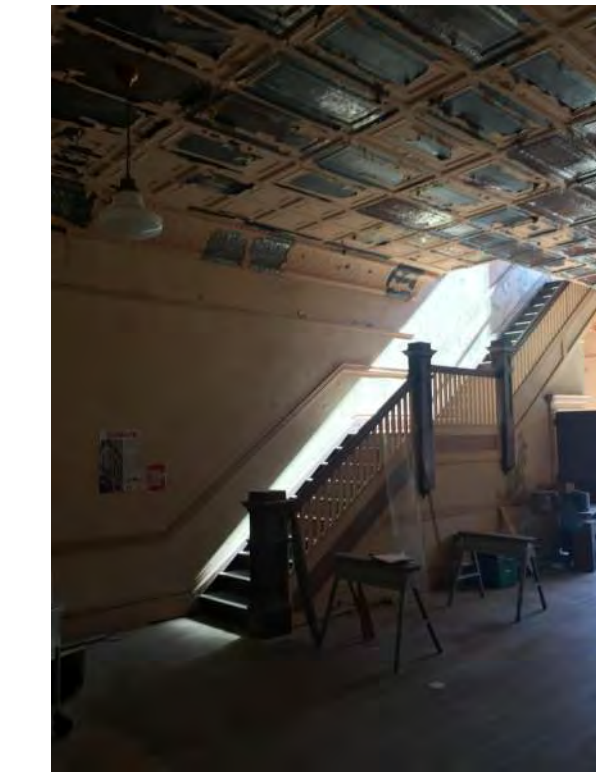

D5 1ST FLOOR STAIRS
SCALE: 12" = 1'-0"



C1 LOOKING FROM BACK
SCALE: 12" = 1'-0"



C2 ROOF IMAGE
SCALE: 12" = 1'-0"



C3 2ND FLOOR STAGE
SCALE: 12" = 1'-0"



C4 2ND FLOOR FIRE PLACE
SCALE: 12" = 1'-0"



C5 2ND FLOOR AT EXIT STR
SCALE: 12" = 1'-0"



B1 STREET ELEVATION PERSPECTIVE
SCALE: 12" = 1'-0"

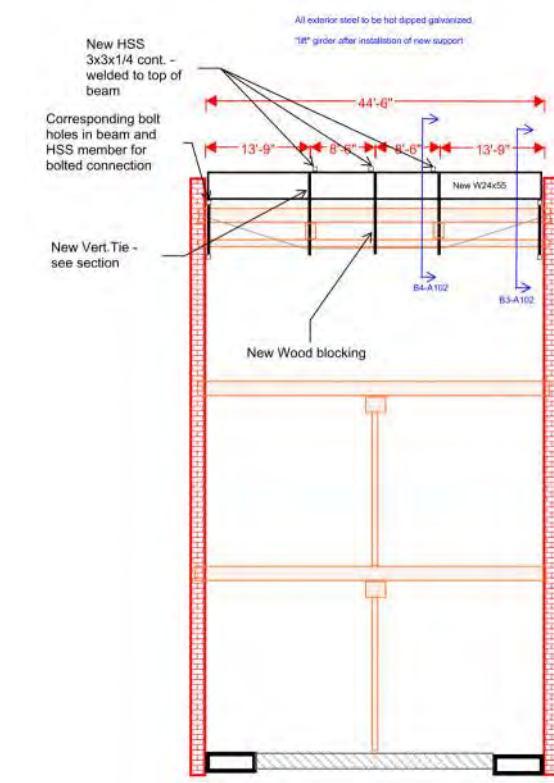

B2 SECTION AT SUPPLEMENTAL SUPPORT BEAM
SCALE: 1/8" = 1'-0"

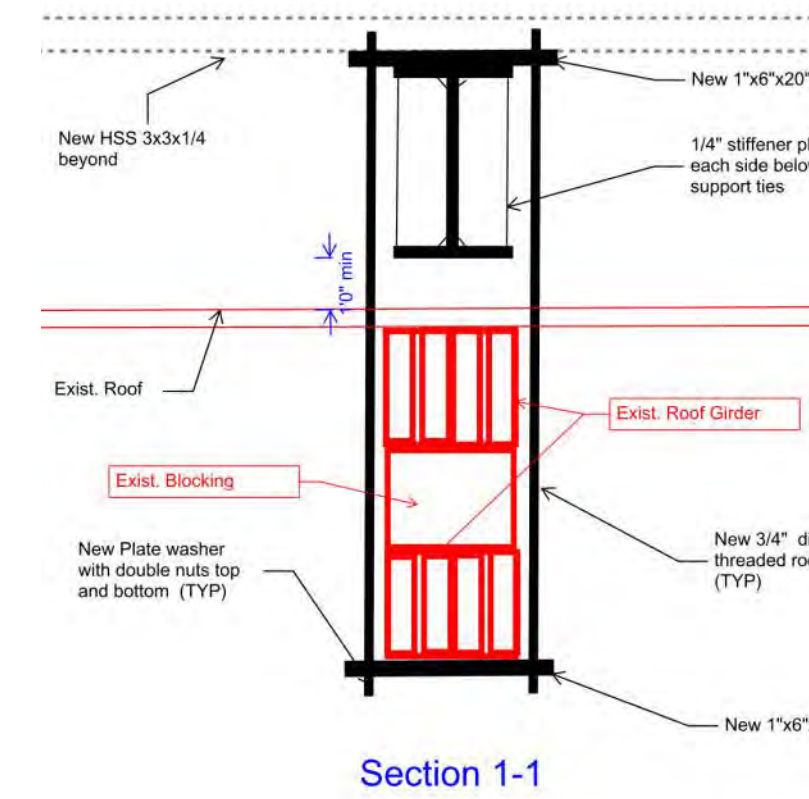

B3 SECTION AT END SUPPORT
SCALE: 1/8" = 1'-0"

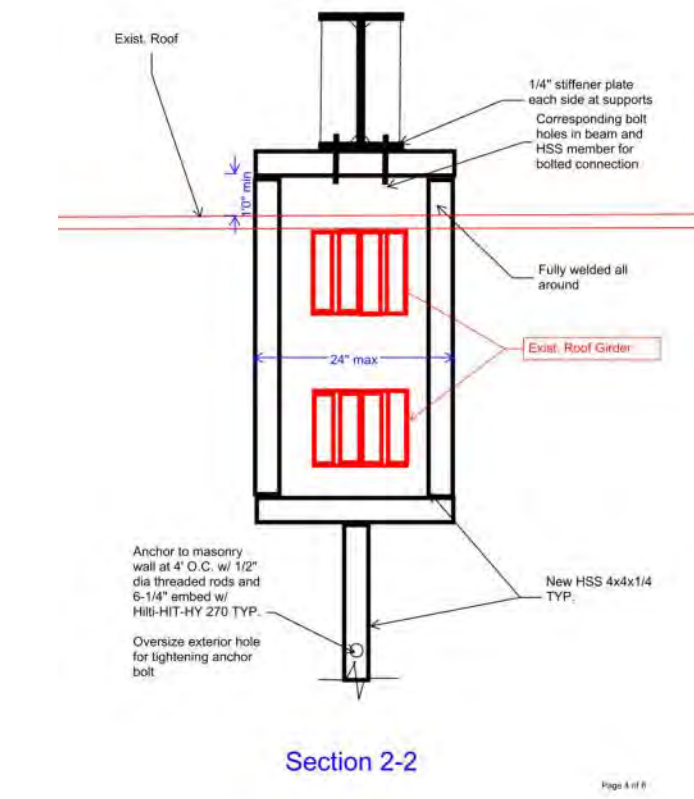

B4 SECTION AT END FRAME SUPPORT
SCALE: 1/8" = 1'-0"

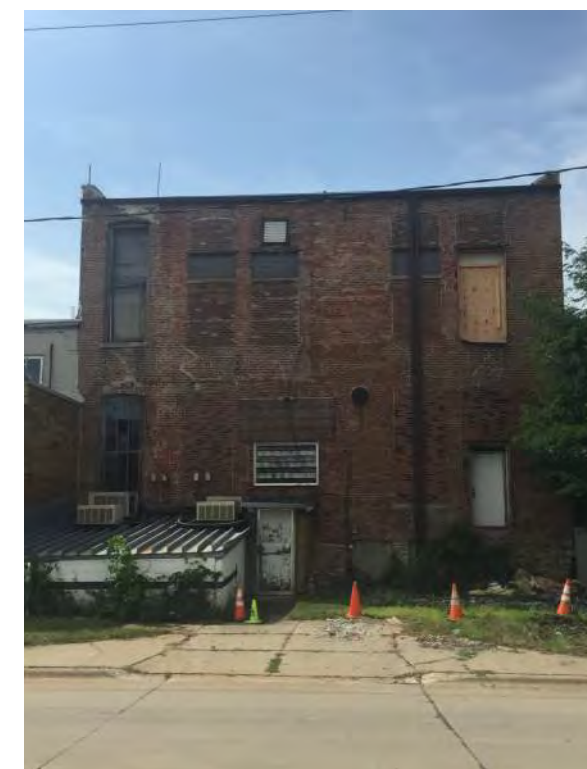

A1 PHOTO AT NORTH
SCALE: 12" = 1'-0"

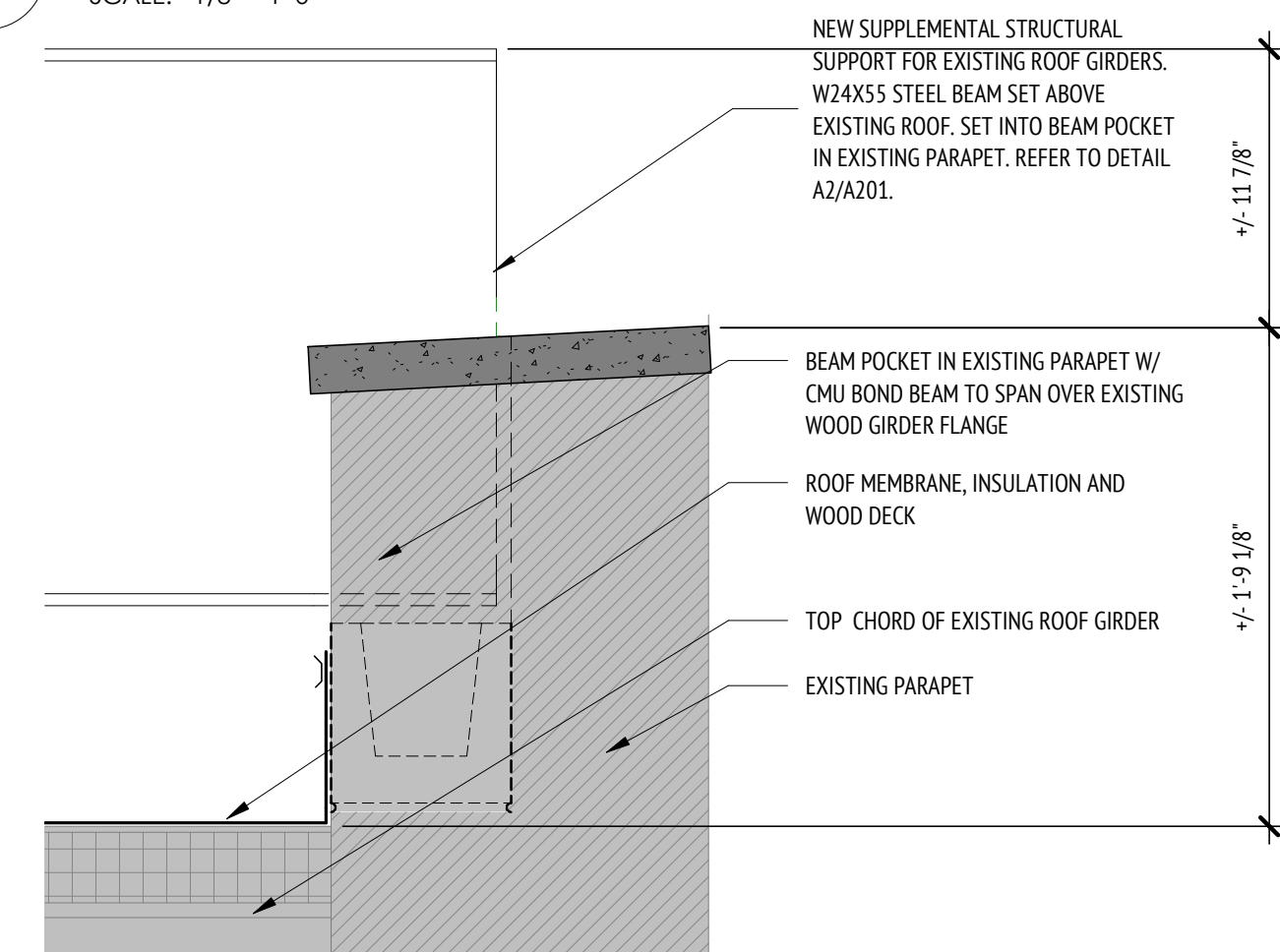

A2 PARAPET DETAIL
SCALE: 1 1/2" = 1'-0"

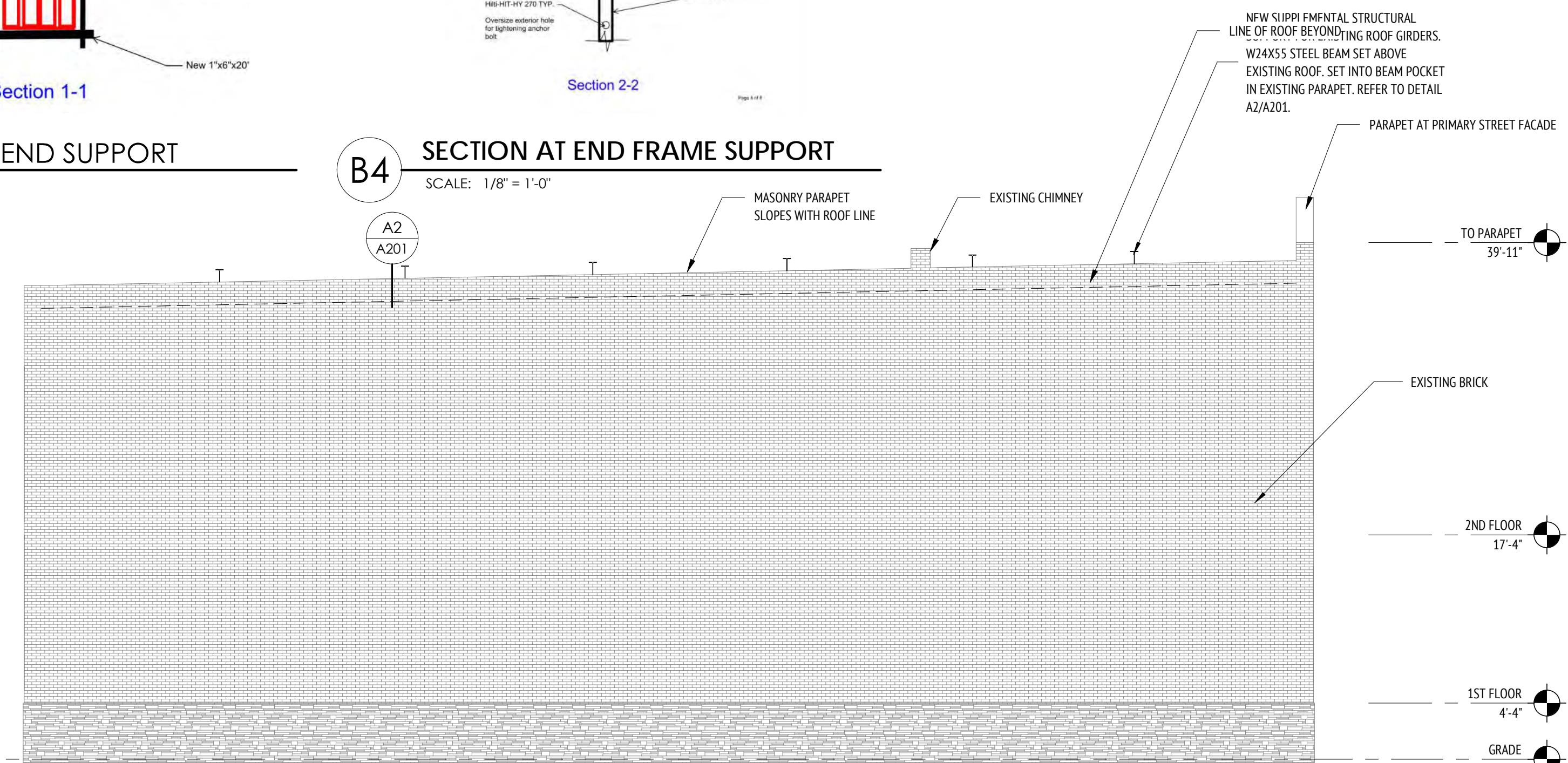

A5 WEST ELEVATION
SCALE: 1/8" = 1'-0"



MEMORANDUM

TO: Ken Wetzler, Public Works Director
Mayor and Council

FROM: Matt Alcazar, Engineering Tech/Project Coordinator

DATE: July 21, 2021

RE: 2021 Tree Stump Removal Service Agreement

SUMMARY: This Agreement is for the 2021 Tree Stump Removal Service. The stumps to be removed are from a list provided by the Electric Utility Line Clearance and Incidents Reports.

PREVIOUS COUNCIL ACTION: Previous Councils have authorized agreements based on a per inch cost for stump removal.

BACKGROUND/DISCUSSION: The contractor will be responsible to complete the current list as soon as possible and to fulfill any future lists of stumps provided by the City until the end of the calendar year. The agreement spells out stumps are to be ground to 12” depth then backfilled with black dirt and seeded.

Requests for proposals were solicited from 12 Tree Stump Removal Contractors (list attached) with 3 being received as follows:

| <u>CONTRACTOR</u> | <u>AMOUNT OF PROPOSAL</u> |
|-----------------------------------|---------------------------|
| Goodpaster Tree Service | \$2.50 per inch |
| Robb’s Tree and Stump Service | \$2.60 per inch |
| Jim’s Tree Service & Construction | \$4.00 per inch |

FINANCIAL IMPLICATIONS:

We have funds available from the Electrical General fund for hiring a contractor to grind the stumps.

RECOMMENDATION: I recommend entering into an agreement with Goodpaster Tree Service, Webster City, Iowa to perform the service.

ALTERNATIVES: We could reject any and all bids and rebid, or perform the service “in house”. However, currently we don’t have the staff or equipment to perform this service.

PUBLIC WORKS DIRECTOR COMMENTS: Recommend approval of the attached resolution to enter into an agreement with Goodpaster Tree Service, 3900 Millards Lane, Webster City, Iowa in the amount of \$2.50 per inch diameter.

RESOLUTION NO. 2021 - _____

AUTHORIZING THE MAYOR AND CITY CLERK TO ENTER INTO AN AGREEMENT WITH GOODPASTER TREE SERVICE, WEBSTER CITY, IOWA PROVIDING FOR 2021 TREE STUMP REMOVAL SERVICES

WHEREAS, requests for proposals were solicited from tree stump removal contractors as required by law for the 2021 Tree Stump Removal Service Agreement; and,

WHEREAS, all of the said proposals have been carefully considered, and it is necessary and advisable that provisions be made for entering into a written agreement for the service;

NOW, THEREFORE, IT IS RESOLVED by the City Council of the City of Webster City, Iowa, as follows:

SECTION 1. The proposal for the service submitted by the following contractor is fully responsive to the plans and specifications for the service, heretofore approved by the Council, and is the lowest responsible proposal received, such proposal being as follows:

| <u>NAME AND ADDRESS OF CONTRACTOR</u> | <u>AMOUNT OF PROPOSAL</u> |
|--|----------------------------------|
| Goodpaster Tree Service, Webster City, Iowa | \$2.50 per inch diameter |

SECTION 2. The agreement for the Services be and the same is hereby entered into with said contractor at the total estimated cost set out above, the final settlement to be made on the basis of the unit prices therein set out and the actual final quantities of each stump removal service furnished. The said agreement is to be subject to the terms of the aforementioned proposal, the plans and specifications and the terms of the bidder's written proposal.

SECTION 3. The Mayor and City Clerk are hereby authorized and directed to enter into a written agreement with said contractor for the project.

BE IT FURTHER RESOLVED that said agreement is hereby approved upon being executed by both parties.

Passed and adopted this 2nd day of August, 2021.

John Hawkins, Mayor

ATTEST:

Karyl K. Bonjour, City Clerk

AGREEMENT FOR CONSTRUCTION SERVICES
2021 Tree Stump Removal Services

This Agreement made and entered on the date hereinafter stated, between the City of Webster City, Iowa, ("City") and Goodpaster Tree Service ("Contractor").

For and in consideration of the mutual covenants contained herein, the parties agree as follows:

1. Scope of Work. Contractor shall perform in a competent and professional manner the Scope of Work as set forth as follows.
 - A. The stump will need to be removed not less than 12" deep. The bid needs to be submitted on a **per inch basis** with the measurement of the stump being taken on the diameter or across the top of it.
 - B. The City right-of-way which includes the chipping and removing of the stump, cleanup of the site, filling the hole back in with dirt to make level with the surrounding ground and seeding.
 - C. The contractor is responsible for calling Iowa One Call to receive the proper locates for each stump to be removed.
 - D. Contractor will supply the Project Coordinator an **Itemized list** of the Stump locations, Inches, and cost of removal.

2. Completion. Contractor shall commence work immediately upon receipt of a written Notice to Proceed from the City and complete all phases of the Scope of Work as expeditiously as is consistent with Contractor skill and care and the orderly progress of the Work in a timely manner. The parties anticipate that all work pursuant to this agreement shall be completed no later than **December 31, 2021**. Upon request of the City, Contractor shall submit, for the City's approval, a schedule for the performance of Contractor's services which shall be adjusted as required as the project proceeds, and which shall include allowances for periods of time required by the City's project coordinator for review and approval of submissions and for approvals of authorities having jurisdiction over the project. This schedule, when approved by the City, shall not, except for reasonable cause, be exceeded by the Contractor.

3. Payment. In consideration of the work performed, City shall pay Contractor on a time and expense basis for all work performed. The unit prices for work performed by Contractor shall not exceed those unit prices set forth in **Itemized list** of Stump locations, Inches, and cost of removal appended hereto. Except as otherwise mutually agreed to by the parties the payments made to Contractor shall not initially exceed \$ 2.50 / inch. Contractor shall submit, in timely fashion, invoices for work performed. The City shall review such invoices and, if they are considered incorrect or untimely, the City shall review the matter with Contractor within ten days from receipt of the Contractor's bill.
 - A. The City of Webster City is set up to pay Accounts Payable (AP) twice each month. All bills are to be approved by the City Council

at their regularly scheduled meetings which are the 1st and 3rd Monday's of each month. The AP checks are mailed out the following day. We will need your invoice by 5:00 p.m. on the Tuesday prior to the council meeting. The invoice you submit for payment must be itemized by stump address/location, diameter of the stump in inches and the cost per stump. You can mail the invoice to my attention at: Project Coordinator, City of Webster City, P.O. Box 217, Webster City, IA 50595; e-mail to malcazar@webstercity.com or fax to 515-832-6686.

4. Non-Assignability. Both parties recognize that this contract is one for personal services and cannot be transferred, assigned, or sublet by either party without prior written consent of the other. Sub-Contracting, if authorized, shall not relieve the Contractor of any of the responsibilities or obligations under this agreement. Contractor shall be and remain solely responsible to the City for the acts, errors, omissions or neglect of any subcontractors' officers, agents and employees, each of whom shall, for this purpose be deemed to be an agent or employee of the Contractor to the extent of the subcontract. The City shall not be obligated to pay or be liable for payment of any sums due which may be due to any sub-contractor.

5. Termination. The Contractor or the City may terminate this Agreement, by giving to the other party thirty (30) days written notice. Contractor shall not be relieved of any liability to the City for damages sustained by the City by virtue of any breach of this Agreement by the Contractor, and the City may withhold any payments to the Contractor for the purposes of set-off until such time as the exact amount of damages due the City from the Contractor may be determined.

6. Covenant Against Contingent Fees. The Contractor warrants that s/he has not employed or retained any company or person, other than a bona fide employee working for the Contractor, to solicit or secure this contract, that s/he has not paid or agreed to pay any company or person, other than a bona fide employee, any fee, commission, percentage, brokerage fee, gifts or any other consideration contingent upon or resulting from the award or making of this contract.

7. Independent Contractor Status. It is expressly acknowledged and understood by the parties that nothing contained in this agreement shall result in, or be construed as establishing an employment relationship. Contractor shall be, and shall perform as, an independent Contractor who agrees to use his or her best efforts to provide the said services on behalf of the City. No agent, employee, or servant of Contractor shall be, or shall be deemed to be, the employee, agent or servant of the City. City is interested only in the results obtained under this contract. The manner and means of conducting the work are under the sole control of Contractor. None of the benefits provided by City to its employees including, but not limited to, workers' compensation insurance and unemployment insurance, are available from City to the employees, agents or servants of Contractor. Contractor shall be solely and entirely responsible for its acts and for the acts of Contractor's agents, employees, servants and subcontractors during the performance of this contract. Contractor shall indemnify City against all liability and loss in connection with, and shall assume full responsibility for payment of all federal, state and local taxes or

contributions imposed or required under unemployment insurance, social security and income tax law, with respect to Contractor and/or Contractor's employees engaged in the performance of the services agreed to herein.

8. Indemnification. Contractor agrees to indemnify and hold harmless the City, its officers, employees, insurers, and self-insurance pool, from and against all liability, claims, and demands, on account of injury, loss, or damage, including without limitation claims arising from bodily injury, personal injury, sickness, disease, death, property loss or damage, or any other loss of any kind whatsoever, which arise out of or are in any manner connected with this contract, if such injury, loss, or damage is caused in whole or in part by, or is claimed to be caused in whole or in part by, the act, omission, error, Contractor error, mistake, negligence, or other fault of the Contractor, any subcontractor of the Contractor, or any officer, employee, representative, or agent of the Contractor or of any subcontractor of the Contractor, or which arises out of any workmen's compensation claim of any employee of the Contractor or of any employee of any subcontractor of the Contractor. The Contractor agrees to investigate, handle, respond to, and to provide defense for and defend against, any such liability, claims or demands at the sole expense of the Contractor. If it is determined by the final judgment of a court of competent jurisdiction agreed between the Parties or decided by any other method that such injury, loss, or damage was caused in whole or in part by the act, omission, or other fault of the City, its officers, or its employees, the City shall reimburse the Contractor for the portion of the judgment attributable to such act, omission, or other fault of the City, its officers, or employees.

9. Contractor Insurance Requirements

- A. Contractor agrees to procure and maintain, at its own expense, a policy or policies of insurance sufficient to insure against all liability, claims, demands, and other obligations assumed by the Contractor pursuant to Section 8 above. Such insurance shall be in addition to any other insurance requirements imposed by this contract or by law. The Contractor shall not be relieved of any liability, claims, demands, or other obligations assumed pursuant to Section 8 above by reason of its failure to procure or maintain insurance, or by reason of its failure to procure or maintain insurance in sufficient amounts, duration, or types.
- B. The contractor shall purchase and maintain such insurance as will protect the Contractor from claims set forth below which may arise out of or result from the Contractor's operations under the contract, whether such operations be by the Contractor or by any subcontractor or by anyone directly or indirectly employed by any of them, or by anyone for whose acts any of them may be liable:
- C. The insurance to be maintained by Contractor shall be written as follows:

Workers Compensation and Employers Liability Insurance as prescribed by Iowa law or the minimum limits shown below

The Workers Compensation policy shall include a *waiver of subrogation clause* in favor of the owner.

Commercial General Liability Insurance Combined Single Limits shown below covering Bodily Injury, Property Damage and Personal Injury:

This insurance must include the following features:

3. The Contractor will need to file with the City Clerk a public liability insurance policy, insuring against any loss that the City or any person may sustain arising out of or in connection with such services performed. The insurance coverage shall include not less than \$10,000.00 property damage, \$25,000.00 for a single personal injury or death and with limits of not less than \$50,000.00 for multiple injuries or death. This coverage shall be in addition to automobile public liability insurance required for any vehicle or equipment operated by the Contractor in conducting business.
4. Additional Insured — The Contractor will include the City or Utility as additional insured on all policies except Workers' Compensation as respects all work performed. The additional insureds shall fully cooperate with the Contractor and its insurers on any claim.
5. Insurance Certificates — Each policy noted above shall be issued by an insurance company authorized to write such insurance in the State of Iowa and shall be reasonably acceptable to the city or utility. These insurance policies shall not be canceled without at least 30 days prior written notice to City or Utility. A properly executed Certificate of Insurance showing evidence of these insurance requirements shall be delivered to the City or Utility prior to the commencement of this Contract.
6. The following clauses will be added to all liability coverages:

The company and the insured expressly agree and state that the purchase of this policy of insurance by the insured does not waive any of the defenses of governmental immunity available to the insured under Iowa Code Section 670.4 as it now exists and as it may be amended from time to time.

The company and the insured further agree that this policy of insurance shall cover only those claims not subject to the defense of governmental immunity under Iowa Code Section 670.4 as it now exists and as it may be amended from time to time.

D. Subrogation:

To the extent that such insurance is in force and collectible and to the extent permitted by law, the City or Utility and Contractor each hereby releases and waives all right of recovery against the other or anyone claiming through or under each of them by way of subrogation or otherwise. The foregoing release and waiver shall apply to damage to contractor's equipment, tools and other personal property as well as automobiles.

- E. The policy or policies required above shall be endorsed to include the City and the City's officers and employees as additional insured. The additional insureds shall fully cooperate with the Contractor and its insurers on any claim. Every policy required above shall be primary insurance, and any insurance carried by the City, its officers or employees, or carried by or provided through any insurance pool of the City, shall be excess and not contributory insurance to that provided by Contractor. No additional insured endorsement to the policy required above shall contain any exclusion for bodily injury or property damage arising from completed operations. The Contractor shall be solely responsible for any deductible losses under any policy required above.
- F. The **certificate of insurance** shall be completed by the Contractor's insurance agent as evidence that policies providing the required coverages, conditions, and minimum limits are in full force and effect, and shall be reviewed and approved by the City prior to commencement of the contract. The certificate shall identify this contract and shall provide that the coverages afforded under the policies shall not be canceled, terminated or materially changed until at least thirty (30) days prior written notice has been given to the City.
- G. Failure on the part of the Contractor to procure or maintain policies providing the required coverages, conditions, and minimum limits shall constitute a material breach of contract upon which City may immediately terminate this contract, or at its discretion City may procure or renew any such policy or any extended reporting period thereto and may pay any and all premiums in connection therewith, and all monies so paid by City shall be repaid by Contractor to City upon demand, or City may offset the cost of the premiums against monies due to Professional from City.
- H. City reserves the right to request and receive a certified copy of any policy any endorsement thereto.
- I. The parties hereto understand and agree that City is relying on, and does not waive or intend to waive by any provision of this contract, or any other rights, immunities, and protections provided by the Iowa Tort Liability of Governmental Subdivisions, Chapter 670, Iowa Code.

10. City's Insurance. The parties hereto understand that the City carries liability insurance for its officers and employees. Copy of said policies is available for inspection upon request during normal business hours.

11. Completeness of Agreement. It is expressly agreed that this agreement contains the entire undertaking of the parties relevant to the subject matter thereof and there are no verbal or written representations, agreements, warranties or promises pertaining to the project matter thereof not expressly incorporated in this writing.

12. Notice. Any written notices as called for herein may be hand delivered to the respective persons and/or addresses listed below or mailed by certified mail return receipt requested, to:

City: Project Coordinator
City of Webster City
P. O. Box 217, 400 Second Street
Webster City, IA 50595

Contractor:
Goodpaster Tree Service
3900 Millards Lane
Webster City, Iowa 50595

13. Non-Discrimination. No discrimination because of race, color, creed, sex, marital status, affectional or sexual orientation, family responsibility, national origin, ancestry, handicap, or religion shall be made in the employment of persons to perform services under this contract.

14. Waiver. The waiver by the City of any term, covenant, or condition hereof shall not operate as a waiver of any subsequent breach of the same or any other term. No term, covenant, or condition of this Agreement can be waived except by the written consent of the City, and forbearance or indulgence by the City in any regard whatsoever shall not constitute a waiver of any term, covenant, or condition to be performed by Contractor to which the same may apply and, until complete performance by Contractor of said term, covenant or condition, the City shall be entitled to invoke any remedy available to it under this Agreement or by law despite any such forbearance or indulgence.

15. Execution of Agreement by City. This agreement shall be binding upon all parties hereto and their respective heirs, executors, administrators, successors, and assigns.

16. General Terms.

(a) It is agreed that neither this agreement nor any of its terms, provisions, conditions, representations or covenants can be modified, changed, terminated or amended, waived, superseded or extended except by appropriate written instrument fully executed by the parties.

(b) If any of the provisions of this agreement shall be held invalid, illegal or unenforceable it shall not affect or impair the validity, legality or enforceability of any other provision.

(c) The parties acknowledge and understand that there are no conditions or limitations to this understanding except those as contained herein at the time of the execution hereof and that after execution no alteration, change or modification shall be made except upon a writing signed by the parties.

(d) This agreement shall be governed by the laws of the State of Iowa as from time to time in effect.

IN WITNESS WHEREOF, the parties hereto have executed, or caused to be executed by their duly authorized officials, this Agreement in three copies each of which shall be deemed an original on the date hereinafter written.

CITY OF WEBSTER CITY, IOWA:

By: _____
John Hawkins

Title: Mayor

Date: _____

ATTEST:

Karyl K. Bonjour, City Clerk

CONTRACTOR:

WITNESSED BY:

Company: _____

By: _____

Title: _____

Date: _____

Arbor Pro
1343 13th Ave. N.
Fort Dodge, Ia. 50501
515-570-5577

Arbor Way All About Trees, LLC
7117 220th St
Colo, Ia. 50056
320-360-2151

Cutting Edge Tree Service
400 Monroe Ave. Suite 8
Mason City, Ia. 50401
641-424-6808

Finco Tree Service
52724 280th
Kelley, Ia. 50134
515-231-4346

Frye's Tree Service
P.O. Box 244
Webster City, Ia. 50595
515-832-3773

Jim's Tree Service
1339 E. Second St.
Webster City, Ia. 50595
515-832-6863

Robb's Tree & Stump Service
228 Summit Dr.
Story City, Ia. 50248
515-520-7175

Weiss Tree Service, Inc.
60953 190th
Navada, Ia. 50201

Wright Tree Service, Inc.
P.O. Box 1718
Des Moines, Ia. 50306
515-277-6291

Powers Tree Service
3363 Zebulon Ave.
Farnhamville, Ia. 50538
515-571-7707

Elite Tree
P.O. Box 145
Tama Ia. 52339
641-651-0194

Goodpaster Tree Service.
3900 Millards Lane.
Webster City, Ia. 50595
515-835-0639



MEMORANDUM

TO: City Manager and City Council

FROM: Brandon Bahrenfuss, Street Department Supervisor

DATE: July 22, 2021

RE: Permission to attend the Public Works Expo in St. Louis, Missouri.

SUMMARY: As the Street Department Supervisor, I'm requesting permission to send myself and the two Street Department Foremen to the Public Work Expo (PWX) in St. Louis, Missouri being held on August 29-September 1, 2021.

PREVIOUS COUNCIL ACTION:

BACKGROUND/DISCUSSION: We are intending to use the City's car and leave Saturday, August 28th and attend the conference Sunday, Monday, Tuesday, and return on Wednesday September 1. PWX provides a first-class multimodal learning experience designed for professionals at all levels. At this conference we will be able to see, hear, touch, and discuss everything public works through work sessions, seminars, workshops, and networking opportunities. We will also attend North America's largest exhibit floor for public works equipment and services. This is a great opportunity to see new and unknown equipment as well as other technologies and how to improve our department moving forward. Seminars include leadership skills, storm sewer, sanitary sewer, water distribution, safety, snow removal, fleet management, streets, roads, bridges, personal development, utilities within right-of-way, construction management, equipment, emergency management, and flood control.

FINANCIAL IMPLICATIONS: With registration, hotel and meals, our anticipated cost per attendee is $\$2,000 \times 3 = \$6,000$.

RECOMMENDATION:

ALTERNATIVES:

PUBLIC WORKS DIRECTOR COMMENTS: This provides an opportunity for our employees who have "feet on the ground" to see other departments' and public works methods and techniques.



WEBSTER
CITY

MEMORANDUM

TO: Mayor and City Council

FROM: Karyl Bonjour, City Clerk

DATE: July 27, 2021

RE: Request from St. Thomas Aquinas Parish for Street Closing for Car Show to be held September 11, 2021 from 11 a.m. to 3:00 p.m.

SUMMARY: Dan Hurt, on behalf of the youth of St. Thomas Aquinas Parish, has requested the following Street to be closed on Saturday, September 11th, 2021 from 10:00 a.m. to 3:00 p.m. for a Car Show. The actual show will be from 11:00 a.m. to 3:00 p.m.

Des Moines Street between Bank Street and Water Street (in front of the Church)

PREVIOUS COUNCIL ACTION: Council has approved similar requests in the past when various organizations/entities have wanted to close streets for events.

BACKGROUND/DISCUSSION: This event would raise money for the youth to attend the National Catholic Youth Conference. I have attached the request which also states they have contacted the School Administration and have been granted permission to use their parking lot as overflow or additional parking. The Street Department would provide barricades/cones/signs as needed.

SUMMARY: This Car Show has turned into an Annual Event as a Fundraiser for the youth of St. Thomas Aquinas and this particular request has been approved by Council in previous years. No Car Show was held last year due to COVID-19. According to the new Policy for Street Closures, Council needs to approve requests affecting Second Street, Des Moines Street, Ohio Street or Beach Street or if time frame is for longer than six hours on any given date.

FINANCIAL IMPLICATIONS: None.

RECOMMENDATION: Approve the request for the closure of Des Moines Street between Bank and Water Streets for the Car Show so the youth can move forward with their plans.

ALTERNATIVE(s): Not approve the request and the youth could find other possible locations/options to have the Car Show.

Dear Karyl,

Once again, I am writing on behalf of St. Thomas Aquinas Parish to seek permission from the city to use a section of Des Moines Street for our annual car show. The youth of St. Thomas Aquinas are in the process of setting up this car show to raise money for the next National Catholic Youth Conference. It will take place on Saturday, September 11 from 11:00 AM – 3:00 PM. If possible, we would once again like to use Des Moines Street between Bank and Water for the car show. I am requesting permission from the city to have Des Moines Street shut down between Bank and Water from 10:00 AM to 3:00 PM on September 11. We have already discussed this with the school administration and have permission to use the middle school parking lot as overflow or additional parking. Thank you for considering this request.

Sincerely,

Dan Hurt, DRE



1000 Des Moines Street

St. Thomas Aquinas

WATER PLANT REPORT FOR THE MONTH OF JUNE 2021

(Production Month-May 2021 Billing Month (Due) - June 2021

| | MONTH June | Year to Date 2021 | MONTH June | Year to Date 2020 |
|--|------------------|----------------------|------------------|----------------------|
| Total Gallons Pumped from Wellsinf | 25,972,000 | 136,370,000 | 24,607,000 | 137,822,000 |
| Average Gallons Pumped | (865,733) | | (820,233) | |
| Gallons for Sludge | 84,600 | 397,150 | 51,700 | 307,850 |
| Total Gallons to Water Plant | 25,887,400 | 135,972,850 | 24,555,300 | 137,514,150 |
| Gallons to Distribution System From From Water Plant (Effluent reading) | 29,493,000 | 153,979,000 | 25,824,000 | 145,818,000 |
| TOTAL TO SYSTEM - CUBIC FEET | 3,942,640 | 20,583,998 | 3,452,166 | 19,493,030 |
| Billed by Clerk's Office to Customers Cubic Feet | 2,789,600 | 14,645,500 | 2,542,900 | 14,198,200 |
| Billed by City Departments Cubic Feet | 355,600 | 1,321,700 | 275,100 | 926,900 |
| Used by City Departments, but not billed-estimated Cubic Feet | | | | |
| Fire | 0 | 0 | 0 | 0 |
| Meter | 0 | 0 | 0 | 0 |
| Sew. Disp. | 0 | 0 | 0 | 0 |
| Street,Water,SewerDistribution,Line Est <i>(main breaks,hydrant flush,sewer, valve rpr,w.tower, line dept</i> | 13,368 | 165,810 | 13,368 | 165,710 |
| Water Plant filter backwash | 127,050 | 762,300 | 127,050 | 762,300 |
| Ground storage tank loss Recreation-Drink.Fount. | 4,400 | 8,947 | 4,400 | 8,947 |
| Cemetery | 400 | 800 | 400 | 800 |
| Change in Distribution System | 0 | 0 | 0 | 0 |
| Used by Contractor | 0 | 0 | 0 | 0 |
| CUBIC FEET UNACCOUNTED FOR | 652,222 | 3,678,941 | 488,948 | 3,430,173 |
| Percentage of Unaccounted for | 16.54% | 18.19% | 14.16% | 17.60% |

NOTE: 36 loads of lime sludge
hauled to farm ground

NOTE: 22 loads of lime sludge
hauled to farm ground

REMARKS:

WASTEWATER TREATMENT PLANT REPORT FOR THE MONTH OF JUNE 2021

| | MONTH June | Year to Date 2021 | MONTH June | Year to Date 2020 | |
|--|---------------|----------------------|---------------|----------------------|--------|
| Total gallons flow | 28,631,500 | 179,746,500 | 46,117,000 | 308,260,000 | gal |
| Average daily flow | 954,000 | | 1,537,000 | | gal/da |
| Percentage treated | 100 | | 100 | | % |
| Total gallons raw sludge | 103,542 | 758,550 | 120,031 | 809,620 | gal |
| Total gallons digested sludge out | 0 | | 0 | | gal |
| Total gallons sludge transferred to storage tank | 172,960 | | 129,380 | | gal |
| Total gallons supernatant returned | 40 | | 0 | | gal |
| Methane gas produced | 31,596 | | 220,654 | | cu.ft. |
| Average effluent CBOD (25 mg/l aver. 40 mg/l max.) | 11.75 | | 5.1 | | mg/l |
| Number of days max. limit was exceeded | 0 | | 0 | | da |
| Average % removal | 97.1 | | 97.2 | | % |
| Average effluent suspended solids (30 mg/l aver. 45 mg/l max.) | 9.7 | | 5.7 | | mg/l |
| Number of days max. limit was exceeded | 0 | | 0 | | da |
| Average percent removal | 97.3 | | 97.4 | | % |
| Average effluent ammonia nitrogen "June"1.3 mg/l average, 14.1 mg/l max. limitation) | 0 | | 0 | | mg/l |
| Number of days max. limit was exceeded | 0 | | 0 | | da |

WATER UTILITY PRODUCTION SALES & USAGE 2021

| Prod Mo. | Billing Month (Due) | Month to Distribution System C/F | Month Billed & Unbilled Usage C/F | Month Unaccounted For C/F | Month Unaccounted For % | Yr to Date To Distribution System C/F | Yr to Date Billed & Unbilled C/F | Yr To Date Unaccounted For C/F | Yr To Date Unaccounted For % |
|---------------|---------------------|----------------------------------|-----------------------------------|---------------------------|-------------------------|---------------------------------------|----------------------------------|--------------------------------|------------------------------|
| Dec | Jan 2021 | 3,127,323 | 2,715,312 | 412,011 | 13.17% | 3,127,323 | 2,715,312 | 412,011 | 13.17% |
| Jan | Feb 2021 | 3,219,028 | 2,579,526 | 639,502 | 19.87% | 6,346,351 | 5,294,838 | 1,051,513 | 16.57% |
| Feb | Mar 2021 | 3,055,269 | 2,643,718 | 411,551 | 13.47% | 9,401,620 | 7,938,556 | 1,463,064 | 15.56% |
| Mar | Apr 2021 | 3,629,427 | 2,729,218 | 900,209 | 24.80% | 13,031,047 | 10,667,774 | 2,363,273 | 18.14% |
| Apr | May 2021 | 3,610,311 | 2,946,865 | 663,446 | 18.38% | 16,641,358 | 13,614,639 | 3,026,719 | 18.19% |
| May | Jun 2021 | 3,942,640 | 3,290,418 | 652,222 | 16.54% | 20,583,998 | 16,905,057 | 3,678,941 | 18.19% |
| June | July 2021 | | | | | | | | |
| July | Aug 2021 | | | | | | | | |
| Aug | Sep 2021 | | | | | | | | |
| Sep | Oct 2021 | | | | | | | | |
| Oct | Nov 2021 | | | | | | | | |
| Nov | Dec 2021 | | | | | | | | |
| TOTALS | | 20,583,998 | 16,905,057 | 3,678,941 | | | | | |

| Billings & Usage By Type of Service-C/F | Used by City Dep i.e. water breaks flush.etc. | | | | | Total | Previous Year | Previous Year Produced |
|--|---|------------------|------------------|------------------|----------------|-------------------|-------------------|---------------------------|
| | Commercial | Industrial | City Depts. | Residential | Not metered | | | |
| Jan 2021 | 626,700 | 436,700 | 143,200 | 1,357,600 | 151,112 | 2,715,312 | 2,720,638 | 3,201,248 |
| Feb 2021 | 624,000 | 362,200 | 144,000 | 1,234,000 | 215,326 | 2,579,526 | 2,535,719 | 3,223,038 |
| Mar 2021 | 728,300 | 365,900 | 188,000 | 1,221,100 | 140,418 | 2,643,718 | 2,453,999 | 3,046,847 |
| Apr 2021 | 679,000 | 426,400 | 260,800 | 1,222,600 | 140,418 | 2,729,218 | 2,601,518 | 3,335,330 |
| May 2021 | 869,200 | 391,700 | 230,100 | 1,310,500 | 145,365 | 2,946,865 | 2,787,765 | 3,234,401 |
| Jun 2021 | 976,600 | 387,600 | 355,600 | 1,425,400 | 145,218 | 3,290,418 | 2,963,218 | 3,452,166 |
| July 2021 | | | | | | | | |
| Aug 2021 | | | | | | | | |
| Sep 2021 | | | | | | | | |
| Oct 2021 | | | | | | | | |
| Nov 2021 | | | | | | | | |
| Dec 2021 | | | | | | | | |
| TOTALS | 4,503,800 | 2,370,500 | 1,321,700 | 7,771,200 | 937,857 | 16,905,057 | 16,062,857 | 19,493,030 |

| BILLING AMOUNT | Commercial Sales | Industrial Sales | City Depts. Sales | Residential Sales | City Depts Not Sold | TOTAL SALES | PREVIOUS YEAR |
|----------------|---------------------|--------------------|--------------------|---------------------|---------------------|---------------------|----------------------|
| Jan 2021 | \$30,188.90 | \$14,925.32 | \$5,080.34 | \$101,377.49 | N/C | \$151,572.05 | \$ 149,828.76 |
| Feb 2021 | \$29,963.33 | \$12,609.74 | \$5,074.60 | \$94,366.33 | N/C | \$142,014.00 | \$ 143,415.60 |
| Mar 2021 | \$33,990.49 | \$12,717.93 | \$6,436.20 | \$93,238.68 | N/C | \$146,383.30 | \$ 137,776.78 |
| Apr 2021 | \$32,191.82 | \$14,582.18 | \$8,753.43 | \$94,849.40 | N/C | \$150,376.83 | \$ 146,410.51 |
| May 2021 | \$38,998.21 | \$13,578.69 | \$7,892.97 | \$99,023.24 | N/C | \$159,493.11 | \$ 154,945.98 |
| Jun 2021 | \$41,995.21 | \$13,388.92 | \$11,897.62 | \$104,969.16 | N/C | \$172,250.91 | \$ 160,774.02 |
| July 2021 | | | | | | | |
| Aug 2021 | | | | | | | |
| Sep 2021 | | | | | | | |
| Oct 2021 | | | | | | | |
| Nov 2021 | | | | | | | |
| Dec 2021 | | | | | | | |
| TOTALS | \$207,327.96 | \$81,802.78 | \$45,135.16 | \$587,824.30 | | \$922,090.20 | \$ 893,151.65 |

| Number of Customers | Commercial | Industrial | City Depts. | Residential | Previous Year | |
|---------------------|------------|------------|-------------|-------------|---------------|-------|
| Jan 2021 | 346 | 9 | 13 | 3,167 | 3,535 | 3,532 |
| Feb 2021 | 344 | 8 | 13 | 3,169 | 3,534 | 3,516 |
| Mar 2021 | 354 | 8 | 13 | 3,170 | 3,545 | 3,523 |
| Apr 2021 | 352 | 8 | 16 | 3,190 | 3,566 | 3,547 |
| May 2021 | 353 | 8 | 17 | 3,182 | 3,560 | 3,538 |
| Jun 2021 | 355 | 8 | 17 | 3,194 | 3,574 | 3,560 |
| July 2021 | | | | | | |
| Aug 2021 | | | | | | |
| Sept 2021 | | | | | | |
| Oct 2021 | | | | | | |
| Nov 2021 | | | | | | |
| Dec 2021 | | | | | | |

Webster City
June 2021 Financial Report
As of June 30, 2021

| Fund Code | Fund Name | Beginning Cash Balance | Beginning Investment Balance | Monthly Revenues | Investments Cash | Transfers | Monthly Expenditures | Investments Purchased | Ending Cash Balance Before Adjustments | Cash Proof | Balance Sheet Adjustments | Ending Cash Balance | Ending Investment Balance | Treasurer's Ending Balance |
|-------------------------------------|---|------------------------|------------------------------|---------------------|------------------|---------------------|----------------------|-----------------------|--|---------------------|---------------------------|---------------------|---------------------------|----------------------------|
| General Fund | | | | | | | | | | | | | | |
| 100 | 100 General | 3,766,320.71 | - | 163,907.63 | - | (175,780.04) | 454,192.87 | - | 3,300,255.43 | 4,465,549.53 | 36,245.79 | 3,336,501.22 | - | 3,336,501.22 |
| | 100A Govern. Equip. Replacement | 45,342.22 | - | 32,899.21 | - | 32,872.13 | 39,406.83 | - | 71,706.73 | - | - | 71,706.73 | - | 71,706.73 |
| | 100B Govern Economic Development | 1,094,405.50 | - | 653.58 | - | - | 37,717.50 | - | 1,057,341.58 | - | - | 1,057,341.58 | - | 1,057,341.58 |
| | Subtotal-General Fund | 4,906,068.43 | - | 197,460.42 | - | (142,907.91) | 531,317.20 | - | 4,429,303.74 | 4,465,549.53 | 36,245.79 | 4,465,549.53 | - | 4,465,549.53 |
| Special Revenue Funds | | | | | | | | | | | | | | |
| 200 | 200 FICA - IPERS | 77,497.89 | - | 4,252.81 | - | - | 22,112.17 | - | 59,638.53 | 59,638.53 | - | 59,638.53 | - | 59,638.53 |
| 201 | 201 Workers compensation | 154,661.06 | - | 1,842.93 | - | - | - | - | 156,503.99 | 156,503.99 | - | 156,503.99 | - | 156,503.99 |
| 202 | 202 Medical/Flex Insurance | 214,044.04 | - | 10,030.88 | - | - | 57,359.04 | - | 166,715.88 | 166,715.88 | - | 166,715.88 | - | 166,715.88 |
| 203 | 203 Unemployment Compensation | 19,581.97 | - | 13.96 | - | - | - | - | 19,595.93 | 19,595.93 | - | 19,595.93 | - | 19,595.93 |
| 204 | 204 Road Use Tax | 1,225,866.63 | - | 105,642.62 | - | 457,444.85 | 61,563.97 | - | 1,727,390.13 | 1,745,641.22 | 18,251.09 | 1,745,641.22 | - | 1,745,641.22 |
| 205 | 205 Airport Commission | (37,092.80) | - | 1,319,584.77 | - | - | 725,471.02 | - | 557,020.95 | 555,907.14 | (1,113.81) | 555,907.14 | - | 555,907.14 |
| 208 | 208 Hotel/Motel Sales Tax | 285,501.07 | - | 170.50 | - | - | 31,088.40 | - | 254,583.17 | 254,583.17 | - | 254,583.17 | - | 254,583.17 |
| 209 | 209 Emergency Levy Fund | 68,061.22 | - | 1,181.27 | - | (69,242.49) | - | - | - | - | - | - | - | - |
| 210 | 210 Police/Fire Retirement Trust Fund | 94,538.83 | - | 3,948.70 | - | - | 20,522.59 | - | 77,964.94 | 77,964.94 | - | 77,964.94 | - | 77,964.94 |
| 211 | 211 DARE Trust | - | - | - | - | - | - | - | - | - | - | - | - | - |
| 212 | 212 Seized Property Trust | - | - | - | - | - | - | - | - | - | - | - | - | - |
| 214 | 214 K9 Trust | 74.26 | - | - | - | - | - | - | 74.26 | 74.26 | - | 74.26 | - | 74.26 |
| 216 | 216 Police Reserve Officers Fund | 3,529.69 | - | 2.11 | - | - | - | - | 3,531.80 | 3,531.80 | - | 3,531.80 | - | 3,531.80 |
| 217 | 217 Wilson Brewer Park/Depot Foundation | 6,785.15 | - | 4.05 | - | - | - | - | 6,789.20 | 6,789.20 | - | 6,789.20 | - | 6,789.20 |
| 218 | 218 Webster City Pride Committee | 4,251.69 | - | - | - | - | - | - | 4,251.69 | 4,251.69 | - | 4,251.69 | - | 4,251.69 |
| 219 | 219 Kendall Young Scout Lodge | 2,764.13 | - | 1.65 | - | - | - | - | 2,765.78 | 2,765.78 | - | 2,765.78 | - | 2,765.78 |
| 220 | 220 Economic Development Revolving | 210,805.87 | - | 153.86 | - | - | 33,616.32 | - | 177,343.41 | 191,419.49 | 14,076.08 | 191,419.49 | - | 191,419.49 |
| 228 | 228 Low/Moderate Income Revolving | 483,038.23 | - | 399.55 | - | 17,930.31 | - | - | 501,368.09 | 502,208.61 | 840.52 | 502,208.61 | - | 502,208.61 |
| 229 | 229 WC Commercial Rehab Rev Loan Program | 151,381.63 | - | 90.41 | - | - | - | - | 151,472.04 | 151,472.04 | - | 151,472.04 | - | 151,472.04 |
| 231 | 231 CDBG Housing Rehab | 16.90 | - | - | - | - | - | - | 16.90 | 16.90 | - | 16.90 | - | 16.90 |
| 232 | 232 B.L.U.E. | 2,442.51 | - | 1.46 | - | - | - | - | 2,443.97 | 2,443.97 | - | 2,443.97 | - | 2,443.97 |
| 240 | 240 USDA Revolving Loan Fund | 182,732.33 | - | 183.95 | - | - | - | - | 182,916.28 | 185,916.28 | 3,000.00 | 185,916.28 | - | 185,916.28 |
| 250 | 250 TIF - Riverview | 26,648.56 | - | 1,538.60 | - | (28,180.37) | - | - | 6.79 | 6.79 | (0.00) | 6.79 | - | 6.79 |
| 251 | 251 TIF - HyVee | 3,726.45 | - | 2.23 | - | - | - | - | 3,728.68 | 3,728.68 | - | 3,728.68 | - | 3,728.68 |
| 255 | 255 TIF - Brewer Creek Estates | 7,455.05 | - | 4.45 | - | (6,725.06) | - | - | 734.44 | 734.44 | - | 734.44 | - | 734.44 |
| 260 | 260 SSMID | 30,426.68 | - | 313.39 | - | 569.00 | 2,862.10 | - | 28,446.97 | 30,086.97 | 1,640.00 | 30,086.97 | - | 30,086.97 |
| 265 | 265 TIF - Struchen | - | - | - | - | - | - | - | - | - | - | - | - | - |
| 268 | 268 TIF - SE Development Park Project | (20,998.39) | - | - | - | - | - | - | (20,998.39) | (20,998.39) | - | (20,998.39) | - | (20,998.39) |
| 272 | 272 TIF - Mitchell Machine | 84.63 | - | - | - | - | - | - | 84.63 | 84.63 | - | 84.63 | - | 84.63 |
| 281 | 281 TIF - Gourley Subdivision | 6,358.20 | - | - | - | (6,358.20) | - | - | - | - | - | - | - | - |
| 282 | 282 TIF - SW Watermain Improvement | 1.96 | - | - | - | - | - | - | 1.96 | 1.96 | - | 1.96 | - | 1.96 |
| 283 | 283 TIF - Town & Country (FSB) | 13,700.28 | - | 8.18 | - | - | - | - | 13,708.46 | 13,708.46 | - | 13,708.46 | - | 13,708.46 |
| 284 | 284 TIF - Fareway Stores | 7,110.08 | - | 4.25 | - | - | - | - | 7,114.33 | 7,114.33 | - | 7,114.33 | - | 7,114.33 |
| 285 | 285 TIF - First State Bank | 6,267.88 | - | 3.74 | - | - | - | - | 6,271.62 | 6,271.62 | - | 6,271.62 | - | 6,271.62 |
| 286 | 286 TIF - Infinity Services LLC | 50,609.96 | - | 30.22 | - | - | - | - | 50,640.18 | 50,640.18 | - | 50,640.18 | - | 50,640.18 |
| 287 | 287 TIF - Webster City Federal | 26,961.23 | - | 16.10 | - | (10,000.00) | (10,000.00) | - | 26,977.33 | 16,977.33 | (10,000.00) | 16,977.33 | - | 16,977.33 |
| 288 | 288 TIF - Van Diest Medical Center | (2,500.00) | - | - | - | - | - | - | (2,500.00) | (2,500.00) | - | (2,500.00) | - | (2,500.00) |
| 289 | 289 TIF - 2013 Medical Complex URA-KTJ (Shopko) | 76,897.42 | - | 45.92 | - | (21,166.66) | - | - | 55,776.68 | 55,776.68 | - | 55,776.68 | - | 55,776.68 |
| 290 | 290 TIF - 3DK Enterprises | 11,068.10 | - | 6.61 | - | - | - | - | 11,074.71 | 11,074.71 | - | 11,074.71 | - | 11,074.71 |
| 291 | 291 TIF - 2016 Industrial - WC Custom Meats | (896.55) | - | - | - | - | - | - | (896.55) | (896.55) | - | (896.55) | - | (896.55) |
| 292 | 292 TIF - Mary Ann's | - | - | - | - | - | - | - | - | - | - | - | - | - |
| 293 | 293 TIF - Tasler's | (1,500.00) | - | - | - | - | - | - | (1,500.00) | (1,500.00) | - | (1,500.00) | - | (1,500.00) |
| 294 | 294 TIF - Ridge Development | 10,597.19 | - | - | - | (9,264.07) | - | - | 1,333.12 | 1,333.12 | - | 1,333.12 | - | 1,333.12 |
| 295 | 295 TIF - Gary & Brenda Fox | (21,166.66) | - | - | - | - | - | - | - | - | - | - | - | - |
| | Subtotal - Special Revenue Funds | 3,381,334.37 | - | 1,449,479.17 | - | 346,173.97 | 944,595.61 | - | 4,232,391.90 | 4,259,085.78 | 26,693.88 | 4,259,085.78 | - | 4,259,085.78 |
| Debt Service Fund | | | | | | | | | | | | | | |
| 300 | 300 Debt Service | 505,864.82 | - | 11,710.43 | - | - | 9,404.30 | - | 508,170.95 | 508,170.95 | - | 508,170.95 | - | 508,170.95 |
| | Subtotal - Debt Service Fund | 505,864.82 | - | 11,710.43 | - | - | 9,404.30 | - | 508,170.95 | 508,170.95 | - | 508,170.95 | - | 508,170.95 |
| Fiduciary & Agency Funds | | | | | | | | | | | | | | |
| 400 | 400 Joe E. Barr Trust | 1,658.50 | - | - | - | - | 28.53 | - | 1,629.97 | 1,658.50 | 28.53 | 1,658.50 | - | 1,658.50 |
| 401 | 401 Edgar Foster Trust | 1,944.55 | - | - | - | - | 28.53 | - | 1,916.02 | 1,944.55 | 28.53 | 1,944.55 | - | 1,944.55 |
| 402 | 402 Calvary Cemetery Trust | 5,112.28 | - | - | - | - | - | - | 5,112.28 | 5,112.28 | - | 5,112.28 | - | 5,112.28 |
| 403 | 403 Zella Silvers Trust | 2,966.12 | - | - | - | - | 28.54 | - | 2,937.58 | 2,966.12 | 28.54 | 2,966.12 | - | 2,966.12 |
| 411 | 411 Mulberry Church | 14,749.82 | - | 386.31 | - | - | - | - | 15,136.13 | 15,136.13 | - | 15,136.13 | - | 15,136.13 |
| 412 | 412 Youth Advisory | 160.00 | - | - | - | - | - | - | 160.00 | 160.00 | - | 160.00 | - | 160.00 |
| 430 | 430 RAGBRAI | - | - | - | - | - | 67.66 | - | (67.66) | 9,932.34 | 10,000.00 | 9,932.34 | - | 9,932.34 |
| | Subtotal - Fiduciary & Agency Funds | 26,591.27 | - | 386.31 | - | - | 153.26 | - | 26,824.32 | 36,909.92 | 10,085.60 | 36,909.92 | - | 36,909.92 |





Webster City
June 2021 Financial Report
As of June 30, 2021

| Fund Code | Fund Name | Beginning Cash Balance | Beginning Investment Balance | Monthly Revenues | Investments Cashed | Transfers | Monthly Expenditures | Investments Purchased | Ending Cash Balance Before Adjustments | Cash Proof | Balance Sheet Adjustments | Ending Cash Balance | Ending Investment Balance | Treasurer's Ending Balance |
|-------------------------------|--|------------------------|------------------------------|------------------|--------------------|----------------|----------------------|-----------------------|--|---------------|---------------------------|---------------------|---------------------------|------------------------------|
| Permanent Fund | | | | | | | | | | | | | | |
| 404 | 404 Perpetual Care Trust (Non-exp.) | 447,001.13 | - | 877.80 | - | - | - | - | 447,878.93 | 447,878.93 | - | 447,878.93 | - | 447,878.93 |
| | Subtotal - Permanent Fund | 447,001.13 | - | 877.80 | - | - | - | - | 447,878.93 | 447,878.93 | - | 447,878.93 | - | 447,878.93 |
| Capital Project Funds | | | | | | | | | | | | | | |
| 500 | 500 Capital Improvement Reserve | 2,719,867.23 | - | 72,488.79 | - | (443,761.00) | - | - | 2,348,595.02 | 2,348,595.02 | - | 2,348,595.02 | - | 2,348,595.02 |
| 502 | 502 Brewer Creek Estates | 1,240.01 | - | 0.75 | - | (1,240.01) | (5,657.03) | - | 5,657.78 | 0.75 | (5,657.03) | 0.75 | - | 0.75 |
| 503 | 503 Boone River Trail | (2,165.00) | - | - | - | - | - | - | (2,165.00) | (2,165.00) | - | (2,165.00) | - | (2,165.00) |
| 504 | 504 Second Street Reconstruction | (573,026.12) | - | - | - | 27,611.37 | - | - | (545,414.75) | (545,414.75) | - | (545,414.75) | - | (545,414.75) |
| 506 | 506 Sidewalk Improvement Fund | 46,130.12 | - | 27.55 | - | - | - | - | 46,157.67 | 46,157.67 | - | 46,157.67 | - | 46,157.67 |
| 525 | 525 Annual Street Maintenance | 1,610.54 | - | - | - | 655,911.40 | 34,322.94 | - | 623,199.00 | 623,199.00 | - | 623,199.00 | - | 623,199.00 |
| 527 | 527 Public Railroad Crossings | 149.30 | - | - | - | - | - | - | 149.30 | 149.30 | - | 149.30 | - | 149.30 |
| 528 | 528 Bridge Improvements | 29,362.36 | - | - | - | - | 2,378.50 | - | 26,983.86 | 27,476.36 | 492.50 | 27,476.36 | - | 27,476.36 |
| 531 | 531 E Second St Sidewalk/Street Improvements | - | - | - | - | - | - | - | - | - | - | - | - | - |
| 532 | 532 James Street (Old Hwy 20) Project | - | - | - | - | - | - | - | - | - | - | - | - | - |
| 533 | 533 Superior Street Sidewalk | - | - | - | - | - | - | - | - | - | - | - | - | - |
| 534 | 534 Wilson-Brewer Park Improvement Project | (462.11) | - | - | - | - | 15,149.92 | - | (15,612.03) | (13,514.61) | 2,097.42 | (13,514.61) | - | (13,514.61) |
| 535 | 535 W Twin Park Shelter Project | (1,340.00) | - | - | - | - | - | - | (1,340.00) | (1,340.00) | - | (1,340.00) | - | (1,340.00) |
| 536 | 536 2020 2nd Street Reconstruction | 5,084,330.04 | - | 3,036.37 | - | - | 724,195.15 | - | 4,363,171.26 | 4,463,171.26 | 100,000.00 | 4,463,171.26 | - | 4,463,171.26 |
| 537 | 537 E Twin Improvements | (142,795.29) | - | - | - | - | 2,506.16 | - | (145,301.45) | (144,181.45) | 1,120.00 | (144,181.45) | - | (144,181.45) |
| | Subtotal - Capital Project Funds | 7,162,901.08 | - | 75,553.46 | - | 238,521.76 | 772,895.64 | - | 6,704,080.66 | 6,802,133.55 | 98,052.89 | 6,802,133.55 | - | 6,802,133.55 |
| Enterprise Funds | | | | | | | | | | | | | | |
| 601 | 601 Electric Utility | 469,688.65 | 300,000.00 | 1,792,292.32 | - | 1,544,882.00 | 3,699,543.38 | - | 107,319.59 | 6,443,304.41 | 1,452,393.67 | 1,559,713.26 | 300,000.00 | 1,859,713.26 |
| 601D | 601D Electric Improvement Reserve | 3,586,588.38 | - | - | - | (820,256.61) | - | - | 2,766,331.77 | - | - | 2,766,331.77 | - | 2,766,331.77 |
| 601E | 601E Project Share Donations | 14,815.53 | - | 84.00 | - | - | - | - | 14,899.53 | - | - | 14,899.53 | - | 14,899.53 |
| 601F | 601F Green City Energy Donations | 2,703.00 | - | 10.00 | - | - | - | - | 2,713.00 | - | - | 2,713.00 | - | 2,713.00 |
| 601G | 601G Green City Energy Donations - Pleasant | 510.00 | - | - | - | - | - | - | 510.00 | - | - | 510.00 | - | 510.00 |
| 601M | 601M Electric Equipment Replacement | 512,412.56 | - | 306.01 | - | - | - | - | 512,718.57 | - | - | 512,718.57 | - | 512,718.57 |
| 601N | 601N Customer Deposit Trust | 388,999.43 | - | 1,850.95 | - | - | - | - | 390,850.38 | - | - | 390,850.38 | - | 390,850.38 |
| 601P | 601P Electric Economic Development | 1,232,549.32 | - | 736.08 | - | - | 37,717.50 | - | 1,195,567.90 | - | - | 1,195,567.90 | - | 1,195,567.90 |
| 601Q | 601Q USDA Elect Revenue Loan | - | - | - | - | - | - | - | - | - | - | - | - | - |
| | Subtotal - Electric Utility Fund | 6,208,266.87 | 300,000.00 | 1,795,279.36 | - | 724,625.39 | 3,737,260.88 | - | 4,990,910.74 | 6,443,304.41 | 1,452,393.67 | 6,443,304.41 | 300,000.00 | 6,743,304.41 |
| 602 | 602 Water Utility | 4,623,190.96 | - | 876,501.94 | - | (556,387.00) | 661,006.78 | - | 4,282,299.12 | 4,264,915.34 | (697,456.66) | 3,584,842.46 | - | 3,584,842.46 |
| 602A | 602A Water Plant Improvements | 54,811.94 | - | - | - | (309,881.85) | (309,881.85) | - | 54,811.94 | - | - | 54,811.94 | - | 54,811.94 |
| 602B | 602B Water Bond Sinking | (465,920.75) | - | - | - | - | - | - | (465,920.75) | - | - | (465,920.75) | - | (465,920.75) |
| 602D | 602D Water Improvement Reserve | 810,393.90 | - | (700,000.00) | - | (162,581.36) | (862,581.36) | - | 810,393.90 | - | - | 810,393.90 | - | 810,393.90 |
| 602E | 602E Water Equipment Replacement | 280,620.20 | - | 167.59 | - | - | - | - | 280,787.79 | - | - | 280,787.79 | - | 280,787.79 |
| | Subtotal - Water Utility Fund | 5,303,096.25 | - | 176,669.53 | - | (1,028,850.21) | (511,456.43) | - | 4,962,372.00 | 4,264,915.34 | (697,456.66) | 4,264,915.34 | - | 4,264,915.34 |
| 603 | 603 Sewer Utility | 1,608,606.40 | 200,000.00 | 665,894.40 | - | (310,767.00) | 536,103.28 | - | 1,427,630.52 | 2,524,140.15 | 33,155.36 | 1,460,785.88 | 200,000.00 | 1,660,785.88 |
| 603A | 603A Sewer Bond Sinking | (3,414.98) | - | - | - | - | - | - | (3,414.98) | - | - | (3,414.98) | - | (3,414.98) |
| 603B | 603B Sewer Bond Reserve | 162,453.30 | - | - | - | - | - | - | 162,453.30 | - | - | 162,453.30 | - | 162,453.30 |
| 603D | 603D Sewer Improvement Reserve | 585,022.24 | - | - | - | (326,796.00) | (336,796.00) | - | 595,022.24 | - | - | 595,022.24 | - | 595,022.24 |
| 603E | 603E Interceptor Sewer Trust | 127,348.44 | - | 76.05 | - | - | - | - | 127,424.49 | - | - | 127,424.49 | - | 127,424.49 |
| 603F | 603F Sewer Equipment Replacement | 181,760.67 | - | 108.55 | - | - | - | - | 181,869.22 | - | - | 181,869.22 | - | 181,869.22 |
| | Subtotal - Sewer Utility Fund | 2,661,776.07 | 200,000.00 | 666,079.00 | - | (637,563.00) | 199,307.28 | - | 2,490,984.79 | 2,524,140.15 | 33,155.36 | 2,524,140.15 | 200,000.00 | 2,724,140.15 |
| | Subtotal - Enterprise Funds | 14,173,139.19 | 500,000.00 | 2,638,027.89 | - | (941,787.82) | 3,425,111.73 | - | 12,444,267.53 | 13,232,359.90 | - | 13,232,359.90 | 500,000.00 | 13,732,359.90 |
| Internal Service Funds | | | | | | | | | | | | | | |
| 902 | 902 Medical/Flex Trust | (45,544.10) | - | 5,257.48 | - | - | - | - | (40,286.62) | (49,768.38) | (9,481.76) | (49,768.38) | - | (49,768.38) |
| | Subtotal - Internal Service Funds | (45,544.10) | - | 5,257.48 | - | - | - | - | (40,286.62) | (49,768.38) | (9,481.76) | (49,768.38) | - | (49,768.38) |
| | Total | 30,557,356.19 | 500,000.00 | 4,378,752.96 | - | (500,000.00) | 5,683,477.74 | - | 28,752,631.41 | | | 29,702,320.18 | 500,000.00 | 30,202,320.18 |
| | | | | | | | | | | | | (1,000.00) | | |
| | | | | | | | | | | | | | | Computer Cash Balance |
| | | | | | | | | | | | | | | 29,701,320.18 |

RETURN SERVICE REQUESTED

CITY OF WEBSTER CITY
400 SECOND ST
PO BOX 217
WEBSTER CITY IA 50595-0217

Managing Your Accounts

-  Customer Service (515)832-1133
-  Telephone Banking (800)260-8419
-  Mailing Address 635 1st Street
Webster City, IA 50595
-  Online Banking www.availa.bank

Summary of Accounts

| Account Type | Account Number | Ending Balance |
|-----------------------|----------------|----------------|
| PUBLIC FUNDS CHECKING | 7021673 | \$500,205.48 |

PUBLIC FUNDS CHECKING-7021673

Account Summary

| Date | Description | Amount |
|------------|---------------------------|---------------------|
| 06/01/2021 | Beginning Balance | \$500,212.33 |
| | 109 Credit(s) This Period | \$7,410,833.79 |
| | 392 Debit(s) This Period | \$7,410,840.64 |
| 06/30/2021 | Ending Balance | \$500,205.48 |

Interest Summary

| Description | Amount |
|--------------------------------|--------------|
| Annual Percentage Yield Earned | 0.50% |
| Interest Days | 30 |
| Interest Earned Not Paid | \$0.00 |
| Interest Paid This Period | \$205.48 |
| Interest Paid Year-to-Date | \$1,239.73 |
| Minimum Balance | \$500,000.00 |

Deposits

| Date | Description | Amount |
|------------|---|--------------|
| 06/01/2021 | Deposit | \$77,250.87 |
| 06/02/2021 | Deposit | \$63,978.50 |
| 06/03/2021 | Transfer Deposit From DDA XXXXXX1682 | \$12,166.07 |
| 06/04/2021 | Deposit | \$22,936.71 |
| 06/04/2021 | Deposit | \$11,865.40 |
| 06/08/2021 | Deposit | \$49,841.93 |
| 06/08/2021 | Deposit | \$106,883.12 |
| 06/09/2021 | Deposit | \$28,455.73 |
| 06/10/2021 | Deposit | \$125,828.92 |
| 06/11/2021 | Deposit | \$67,121.77 |
| 06/14/2021 | Deposit | \$91,575.41 |
| 06/14/2021 | Transfer Deposit From DDA XXXXXX1682 | \$453,738.01 |
| 06/15/2021 | Deposit | \$30,814.27 |
| 06/15/2021 | Deposit | \$1,698.18 |
| 06/16/2021 | Deposit | \$9,372.78 |
| 06/16/2021 | Transfer Deposit From DDA XXXXXX1682 | \$86,570.28 |
| 06/17/2021 | Deposit | \$19,976.79 |
| 06/17/2021 | Transfer Deposit From DDA XXXXXX1682 | \$242,453.87 |
| 06/18/2021 | Deposit | \$38,442.31 |
| 06/21/2021 | Deposit | \$44,078.47 |

2010 N. Ankeny Blvd.
Ankeny, IA 50023

PUBLIC FUNDS CHECKING-7021673 (continued)

Deposits (continued)

| Date | Description | Amount |
|-------------|---|---------------|
| 06/22/2021 | Deposit | \$41,256.85 |
| 06/23/2021 | Deposit | \$14,705.41 |
| 06/23/2021 | Transfer Deposit From DDA XXXXXX1682 | \$602,956.62 |
| 06/24/2021 | Deposit | \$18,734.92 |
| 06/24/2021 | Transfer Deposit From DDA XXXXXX1682 | \$196,948.28 |
| 06/25/2021 | Deposit | \$21,532.27 |
| 06/28/2021 | Deposit | \$27,367.26 |
| 06/28/2021 | Dep Item Rtn ACH Webster City PAYROLL HISLER, KATHY J. | \$0.00 |
| 06/28/2021 | Transfer Deposit From DDA XXXXXX1682 | \$129,249.45 |
| 06/29/2021 | Deposit | \$33,038.63 |
| 06/29/2021 | Transfer Deposit From DDA XXXXXX1682 | \$69,823.84 |
| 06/30/2021 | Deposit | \$28,674.16 |
| 06/30/2021 | Transfer Deposit From DDA XXXXXX1682 | \$2,370.26 |
| 06/30/2021 | Accr Earning Pymt Added to Account | \$205.48 |

Electronic Credits

| Date | Description | Amount |
|-------------|---|----------------|
| 06/01/2021 | ACH Deposit FCSAMERICA FCSA AFCSA EXP CITY OF WEBSTER CI | \$1,174.03 |
| 06/01/2021 | ACH Deposit GRAND TRUNK WEST PAYMENT CITY OF WEBSTER CIT | \$845.30 |
| 06/01/2021 | ACH Deposit PAYMENTECH DEPOSIT Webster Service Fee | \$0.69 |
| 06/01/2021 | ACH Deposit PAYMENTECH DEPOSIT Webster City Govt | \$25.00 |
| 06/01/2021 | ACH Deposit PAYMENTECH DEPOSIT CITY OF WEBSTER CITY | \$3,009.33 |
| 06/01/2021 | ACH Deposit PAYMENTECH DEPOSIT CITY OF WEBSTER CITY | \$572.04 |
| 06/01/2021 | ACH Deposit PAYMENTECH DEPOSIT CITY OF WEBSTER CITY | \$2,579.00 |
| 06/01/2021 | ACH Deposit PAYMENTECH DEPOSIT Webster City Govt | \$68.00 |
| 06/01/2021 | ACH Deposit PAYMENTECH DEPOSIT CITY OF WEBSTER CITY | \$557.49 |
| 06/01/2021 | ACH Deposit WEBSTER CITY CREDITS Webster City | \$583,288.23 |
| 06/02/2021 | ACH Deposit PAYMENTECH DEPOSIT CITY OF WEBSTER CITY | \$800.04 |
| 06/02/2021 | ACH Deposit UMB-KANSAS CITY TRUST DEPT UMB BANK AS FIDUC | \$2,098,606.25 |
| 06/03/2021 | ACH Deposit PAYMENTECH DEPOSIT Webster City Govt | \$150.00 |
| 06/03/2021 | ACH Deposit PAYMENTECH DEPOSIT CITY OF WEBSTER CITY | \$2,356.25 |
| 06/04/2021 | ACH Deposit PAYMENTECH DEPOSIT Webster City Govt | \$94.50 |
| 06/04/2021 | ACH Deposit PAYMENTECH DEPOSIT CITY OF WEBSTER CITY | \$1,721.99 |
| 06/04/2021 | ACH Deposit THRIFTY WHITE DIRECT PAY City Of Webster Cit | \$555.25 |

2010 N. Ankeny Blvd.
Ankeny, IA 50023

PUBLIC FUNDS CHECKING-7021673 (continued)

Electronic Credits (continued)

| Date | Description | Amount |
|-------------|---|---------------|
| 06/07/2021 | ACH Deposit CAPTURIS BILL PAY CITY OF WEBSTER | \$806.92 |
| 06/07/2021 | ACH Deposit PAYMENTECH DEPOSIT Webster City Govt | \$63.00 |
| 06/07/2021 | ACH Deposit PAYMENTECH DEPOSIT CITY OF WEBSTER CITY | \$3,323.37 |
| 06/08/2021 | ACH Deposit FIRST STATE BANK CASH TRANS CITY OF WEBSTER | \$20.83 |
| 06/08/2021 | ACH Deposit PAYMENTECH DEPOSIT CITY OF WEBSTER CITY | \$3,535.43 |
| 06/08/2021 | ACH Deposit PAYMENTECH DEPOSIT Webster City Govt | \$31.50 |
| 06/08/2021 | ACH Deposit PAYMENTECH DEPOSIT CITY OF WEBSTER CITY | \$3,052.75 |
| 06/08/2021 | ACH Deposit PAYMENTECH DEPOSIT CITY OF WEBSTER CITY | \$189.00 |
| 06/08/2021 | ACH Deposit THE HANOR CO WI PAYABLES CITY OF WEBSTER CIT | \$768.45 |
| 06/09/2021 | ACH Deposit GRAND TRUNK WEST PAYMENT CITY OF WEBSTER CIT | \$1,058.27 |
| 06/09/2021 | ACH Deposit PAYMENTECH DEPOSIT CITY OF WEBSTER CITY | \$3,578.59 |
| 06/10/2021 | ACH Deposit Corn Belt Power AP CITY OF WEBSTER CITY | \$236.70 |
| 06/10/2021 | ACH Deposit PAYMENTECH DEPOSIT Webster City Govt | \$456.25 |
| 06/10/2021 | ACH Deposit PAYMENTECH DEPOSIT CITY OF WEBSTER CITY | \$1,353.50 |
| 06/10/2021 | ACH Deposit PAYMENTECH DEPOSIT Webster Service Fee | \$12.54 |
| 06/10/2021 | ACH Deposit Webster City UTILITY CITY OF WEBSTER CITY U | \$122,616.68 |
| 06/11/2021 | ACH Deposit PAYMENTECH DEPOSIT CITY OF WEBSTER CITY | \$2,459.28 |
| 06/11/2021 | ACH Deposit ST OF IA-E.F.T. E.F.T. WEBSTER CITY CITY OF | \$187.93 |
| 06/14/2021 | ACH Deposit PAYMENTECH DEPOSIT CITY OF WEBSTER CITY | \$4,471.54 |
| 06/15/2021 | ACH Deposit HAMILTON COUNTY Treas Ord Webster City Corp. | \$73,053.78 |
| 06/15/2021 | ACH Deposit MARY ANNS SPECIA WC USDA CITY OF WEBSTER CIT | \$8,403.36 |
| 06/15/2021 | ACH Deposit PAYMENTECH DEPOSIT CITY OF WEBSTER CITY | \$3,538.57 |
| 06/15/2021 | ACH Deposit PAYMENTECH DEPOSIT CITY OF WEBSTER CITY | \$337.00 |
| 06/15/2021 | ACH Deposit ST OF IA-E.F.T. E.F.T. WEBSTER CITY CITY OF | \$104,910.53 |
| 06/16/2021 | ACH Deposit CAPTURIS BILL PAY CITY OF WEBSTER | \$10,576.56 |
| 06/16/2021 | ACH Deposit PAYMENTECH DEPOSIT Webster Service Fee | \$4.78 |
| 06/16/2021 | ACH Deposit PAYMENTECH DEPOSIT Webster City Govt | \$174.00 |
| 06/16/2021 | ACH Deposit PAYMENTECH DEPOSIT CITY OF WEBSTER CITY | \$1,735.79 |
| 06/17/2021 | ACH Deposit PAYMENTECH DEPOSIT CITY OF WEBSTER CITY | \$1,411.30 |

2010 N. Ankeny Blvd.
Ankeny, IA 50023

PUBLIC FUNDS CHECKING-7021673 (continued)

Electronic Credits (continued)

| Date | Description | Amount |
|-------------|--|----------------|
| 06/18/2021 | ACH Deposit Corn Belt Power AP CITY OF WEBSTER CITY | \$90,323.64 |
| 06/18/2021 | ACH Deposit MARY ANNS SPECIA WC ECONOMI WEBSTER CITY | \$14,104.05 |
| 06/18/2021 | ACH Deposit PAYMENTECH DEPOSIT CITY OF WEBSTER CITY | \$1,103.72 |
| 06/21/2021 | ACH Deposit PAYMENTECH DEPOSIT CITY OF WEBSTER CITY | \$1,535.96 |
| 06/21/2021 | ACH Deposit Webster City UTILITY CITY OF WEBSTER CITY U | \$53,493.15 |
| 06/22/2021 | ACH Deposit FAA TREAS 310 MISC PAY WEBSTER CITY IA CITY | \$195,461.15 |
| 06/22/2021 | ACH Deposit PAYMENTECH DEPOSIT Webster Service Fee | \$56.51 |
| 06/22/2021 | ACH Deposit PAYMENTECH DEPOSIT CITY OF WEBSTER CITY | \$4,411.08 |
| 06/22/2021 | ACH Deposit PAYMENTECH DEPOSIT CITY OF WEBSTER CITY | \$1,088.09 |
| 06/22/2021 | ACH Deposit PAYMENTECH DEPOSIT CITY OF WEBSTER CITY | \$1,279.53 |
| 06/23/2021 | ACH Deposit PAYMENTECH DEPOSIT CITY OF WEBSTER CITY | \$4,311.33 |
| 06/23/2021 | ACH Deposit PAYMENTECH DEPOSIT Webster City Govt | \$55.00 |
| 06/23/2021 | ACH Deposit PAYMENTECH DEPOSIT Webster Service Fee | \$1.51 |
| 06/24/2021 | ACH Deposit PAYMENTECH DEPOSIT CITY OF WEBSTER CITY | \$1,749.87 |
| 06/24/2021 | ACH Deposit PAYMENTECH DEPOSIT Webster Service Fee | \$1.65 |
| 06/24/2021 | ACH Deposit PAYMENTECH DEPOSIT Webster City Govt | \$60.00 |
| 06/25/2021 | ACH Deposit FAA TREAS 310 MISC PAY WEBSTER CITY IA CITY | \$1,120,923.79 |
| 06/25/2021 | ACH Deposit PAYMENTECH DEPOSIT CITY OF WEBSTER CITY | \$1,126.50 |
| 06/28/2021 | ACH Deposit NORTH IOWA MUNIC ACH Paymen Webster City | \$19,316.02 |
| 06/28/2021 | ACH Deposit PAYMENTECH DEPOSIT CITY OF WEBSTER CITY | \$2,137.53 |
| 06/29/2021 | ACH Deposit PAYMENTECH DEPOSIT CITY OF WEBSTER CITY | \$2,461.33 |
| 06/29/2021 | ACH Deposit PAYMENTECH DEPOSIT Webster City Govt | \$135.00 |
| 06/29/2021 | ACH Deposit PAYMENTECH DEPOSIT Webster Service Fee | \$3.71 |
| 06/29/2021 | ACH Deposit PAYMENTECH DEPOSIT CITY OF WEBSTER CITY | \$1,239.68 |
| 06/29/2021 | ACH Deposit PAYMENTECH DEPOSIT CITY OF WEBSTER CITY | \$624.24 |
| 06/29/2021 | ACH Deposit ST OF IA-E.F.T. E.F.T. WEBSTER CITY CITY OF | \$70,846.95 |
| 06/30/2021 | ACH Deposit PAYMENTECH DEPOSIT CITY OF WEBSTER CITY | \$2,274.76 |
| 06/30/2021 | ACH Deposit PAYMENTECH DEPOSIT Webster Service Fee | \$0.63 |
| 06/30/2021 | ACH Deposit PAYMENTECH DEPOSIT Webster City Govt | \$23.00 |

2010 N. Ankeny Blvd.
Ankeny, IA 50023

PUBLIC FUNDS CHECKING-7021673 (continued)

Electronic Debits

| Date | Description | Amount |
|-------------|---|---------------|
| 06/01/2021 | ACH Payment IA CHILD SUPPORT CHILD SUPP CITY OF WEBSTER | \$532.14 |
| 06/01/2021 | ACH Payment IA DEPT OF REV IA REV PAY WEBSTER CITY CITY | \$6,736.00 |
| 06/01/2021 | ACH Payment RUAN, INCORPORAT PAYMENTS CITY OF WEBSTER CI | \$3,990.33 |
| 06/03/2021 | ACH Payment PAYMENTECH FEE Webster Service Fee | \$30.04 |
| 06/03/2021 | ACH Payment PAYMENTECH FEE Webster City Govt | \$38.62 |
| 06/04/2021 | ACH Payment Xpress Bill Pay BILLING Webster City | \$532.67 |
| 06/10/2021 | ACH Payment Webster City PAYROLL CITY OF WEBSTER CITY | \$119,541.02 |
| 06/11/2021 | ACH Payment IA DEPT OF REV IA REV PAY WEBSTER CITY CITY | \$4,109.00 |
| 06/11/2021 | ACH Payment IA DEPT OF REV IA REV PAY WEBSTER CITY CITY | \$19,803.00 |
| 06/14/2021 | ACH Payment IA CHILD SUPPORT CHILD SUPP CITY OF WEBSTER | \$532.14 |
| 06/14/2021 | ACH Payment IA DEPT OF REV IA REV PAY WEBSTER CITY CITY | \$6,880.00 |
| 06/15/2021 | ACH Payment IRS USATAXPYMT CITY OF WEBSTER CITY | \$36,418.61 |
| 06/21/2021 | ACH Payment CITY OF WEBSTER USDA TRANS CHECKING * * * 1673 | \$3,000.00 |
| 06/23/2021 | ACH Payment NORTH IOWA MUNIC ACH Collec Webster City | \$618,891.34 |
| 06/24/2021 | ACH Payment IA DEPT OF REV IA REV PAY WEBSTER CITY CITY | \$11,076.00 |
| 06/24/2021 | ACH Payment IA DEPT OF REV IA REV PAY WEBSTER CITY CITY | \$3,594.00 |
| 06/24/2021 | ACH Payment USDA RD RUS PAYMENT WEBSTER CITY, CITY | \$16,806.72 |
| 06/24/2021 | ACH Payment Webster City PAYROLL CITY OF WEBSTER CITY | \$121,769.86 |
| 06/25/2021 | ACH Payment UMB CORP TRUST 6-21 Fees WEBSTER CITY 16A | \$250.00 |
| 06/25/2021 | ACH Payment UMB CORP TRUST 6-21 Fees WEBSTER CITY 12 | \$250.00 |
| 06/28/2021 | ACH Payment IRS USATAXPYMT CITY OF WEBSTER CITY | \$2,682.40 |
| 06/28/2021 | ACH Payment IRS USATAXPYMT CITY OF WEBSTER CITY | \$37,289.95 |
| 06/28/2021 | ACH Payment IA CHILD SUPPORT CHILD SUPP CITY OF WEBSTER | \$532.14 |
| 06/28/2021 | ACH Payment IA DEPT OF REV IA REV PAY WEBSTER CITY CITY | \$6,996.00 |
| 06/28/2021 | ACH Payment IPERS PAYROLL CITY OF WEBSTER CITY | \$39,839.41 |

Other Debits

| Date | Description | Amount |
|-------------|--|----------------|
| 06/01/2021 | Transfer Withdrawal To DDA XXXXXX1682 | \$618,288.54 |
| 06/02/2021 | Transfer Withdrawal To DDA XXXXXX1682 | \$2,111,368.72 |

2010 N. Ankeny Blvd.
Ankeny, IA 50023

PUBLIC FUNDS CHECKING-7021673 (continued)

Other Debits (continued)

| Date | Description | Amount |
|------------|--|--------------|
| 06/04/2021 | Transfer Withdrawal To DDA XXXXXX1682 | \$25,534.97 |
| 06/07/2021 | Transfer Withdrawal To DDA XXXXXX1682 | \$3,827.88 |
| 06/08/2021 | Transfer Withdrawal To DDA XXXXXX1682 | \$162,194.51 |
| 06/09/2021 | Transfer Withdrawal To DDA XXXXXX1682 | \$26,310.05 |
| 06/10/2021 | Deposit Item Ret CHARGE BACK CK-DONOVAN CUSEY-NSF | \$1,698.18 |
| 06/10/2021 | Transfer Withdrawal To DDA XXXXXX1682 | \$34,032.71 |
| 06/10/2021 | Dep Item Ret Chrg | \$5.00 |
| 06/11/2021 | Transfer Withdrawal To DDA XXXXXX1682 | \$1,672.21 |
| 06/14/2021 | Deposit Item Ret RETURN CHECK-WAYNE TAPPER-NSF | \$365.51 |
| 06/14/2021 | Dep Item Ret Chrg | \$5.00 |
| 06/15/2021 | Transfer Withdrawal To DDA XXXXXX1682 | \$60,665.89 |
| 06/18/2021 | Transfer Withdrawal To DDA XXXXXX1682 | \$26,274.98 |
| 06/21/2021 | Transfer Withdrawal To DDA XXXXXX1682 | \$94,532.76 |
| 06/22/2021 | Transfer Withdrawal To DDA XXXXXX1682 | \$243,054.99 |
| 06/25/2021 | Transfer Withdrawal To DDA XXXXXX1682 | \$182,572.76 |
| 06/28/2021 | Deposit Item Ret RTN CHECK- ACCT CLOSED- DR SAHAI | \$73.00 |
| 06/28/2021 | Dep Item Ret Chrg | \$5.00 |





Checks Cleared

| Check Nbr | Date | Amount | Check Nbr | Date | Amount | Check Nbr | Date | Amount |
|-----------|------------|----------|-----------|------------|-------------|-----------|------------|----------|
| 2237 | 06/14/2021 | \$8.31 | 2634 | 06/01/2021 | \$8.08 | 2660 | 06/14/2021 | \$441.25 |
| 2474* | 06/14/2021 | \$16.62 | 2635 | 06/15/2021 | \$34.17 | 2661 | 06/15/2021 | \$660.48 |
| 2594* | 06/15/2021 | \$102.13 | 2636 | 06/03/2021 | \$72.61 | 2662 | 06/15/2021 | \$194.16 |
| 2596* | 06/07/2021 | \$18.47 | 2637 | 06/03/2021 | \$68.69 | 2663 | 06/15/2021 | \$89.70 |
| 2598* | 06/02/2021 | \$110.82 | 2638 | 06/02/2021 | \$65.00 | 2664 | 06/22/2021 | \$51.43 |
| 2600* | 06/07/2021 | \$226.62 | 2639 | 06/01/2021 | \$28,345.49 | 2665 | 06/28/2021 | \$96.97 |
| 2601 | 06/14/2021 | \$73.88 | 2640 | 06/03/2021 | \$32.00 | 2666 | 06/15/2021 | \$56.56 |
| 2611* | 06/15/2021 | \$51.26 | 2641 | 06/02/2021 | \$215.00 | 2667 | 06/16/2021 | \$105.80 |
| 2618* | 06/15/2021 | \$51.56 | 2642 | 06/28/2021 | \$46.12 | 2668 | 06/28/2021 | \$79.02 |
| 2619 | 06/04/2021 | \$36.94 | 2643 | 06/21/2021 | \$92.35 | 2669 | 06/15/2021 | \$236.11 |
| 2621* | 06/07/2021 | \$120.32 | 2645* | 06/16/2021 | \$73.88 | 2670 | 06/17/2021 | \$65.00 |
| 2622 | 06/02/2021 | \$55.41 | 2647* | 06/16/2021 | \$312.82 | 2671 | 06/16/2021 | \$32.50 |
| 2623 | 06/02/2021 | \$68.75 | 2648 | 06/17/2021 | \$92.35 | 2672 | 06/15/2021 | \$215.00 |
| 2625* | 06/14/2021 | \$18.47 | 2649 | 06/16/2021 | \$85.94 | 2674* | 06/29/2021 | \$36.94 |
| 2626 | 06/03/2021 | \$85.94 | 2652* | 06/15/2021 | \$68.75 | 2675 | 06/29/2021 | \$457.21 |
| 2627 | 06/04/2021 | \$85.94 | 2653 | 06/17/2021 | \$85.94 | 2677* | 06/29/2021 | \$85.94 |
| 2628 | 06/02/2021 | \$92.35 | 2654 | 06/15/2021 | \$55.41 | 2678 | 06/30/2021 | \$658.82 |
| 2629 | 06/14/2021 | \$702.19 | 2655 | 06/15/2021 | \$589.55 | 2679 | 06/29/2021 | \$68.75 |
| 2630 | 06/03/2021 | \$202.01 | 2656 | 06/23/2021 | \$52.53 | 2680 | 06/29/2021 | \$51.56 |
| 2631 | 06/15/2021 | \$8.31 | 2657 | 06/15/2021 | \$409.11 | 2684* | 06/29/2021 | \$663.43 |
| 2632 | 06/02/2021 | \$210.35 | 2658 | 06/15/2021 | \$38.45 | 2685 | 06/29/2021 | \$169.44 |
| 2633 | 06/01/2021 | \$125.60 | 2659 | 06/14/2021 | \$964.95 | 2686 | 06/28/2021 | \$579.92 |

RETURN SERVICE REQUESTED

CITY OF WEBSTER CITY
SWEEP ACCOUNT
400 SECOND ST
PO BOX 217
WEBSTER CITY IA 50595-0217

Managing Your Accounts

-  Customer Service (515)832-1133
-  Telephone Banking (800)260-8419
-  Mailing Address 635 1st Street
Webster City, IA 50595
-  Online Banking www.availa.bank

Summary of Accounts

| Account Type | Account Number | Ending Balance |
|-----------------------|----------------|-----------------|
| PUBLIC FUNDS CHECKING | 7021682 | \$29,412,095.11 |

PUBLIC FUNDS CHECKING-7021682

Account Summary

| Date | Description | Amount |
|------------|--------------------------|------------------------|
| 06/01/2021 | Beginning Balance | \$27,599,059.31 |
| | 14 Credit(s) This Period | \$3,609,312.48 |
| | 9 Debit(s) This Period | \$1,796,276.68 |
| 06/30/2021 | Ending Balance | \$29,412,095.11 |

Interest Summary

| Description | Amount |
|--------------------------------|-----------------|
| Annual Percentage Yield Earned | 0.77% |
| Interest Days | 30 |
| Interest Earned Not Paid | \$0.00 |
| Interest Paid This Period | \$18,981.51 |
| Interest Paid Year-to-Date | \$103,037.58 |
| Minimum Balance | \$28,217,347.85 |

Deposits

| Date | Description | Amount |
|------------|---|----------------|
| 06/01/2021 | Transfer Deposit From DDA XXXXXX1673 | \$618,288.54 |
| 06/02/2021 | Transfer Deposit From DDA XXXXXX1673 | \$2,111,368.72 |
| 06/04/2021 | Transfer Deposit From DDA XXXXXX1673 | \$25,534.97 |
| 06/07/2021 | Transfer Deposit From DDA XXXXXX1673 | \$3,827.88 |
| 06/08/2021 | Transfer Deposit From DDA XXXXXX1673 | \$162,194.51 |
| 06/09/2021 | Transfer Deposit From DDA XXXXXX1673 | \$26,310.05 |
| 06/10/2021 | Transfer Deposit From DDA XXXXXX1673 | \$34,032.71 |
| 06/11/2021 | Transfer Deposit From DDA XXXXXX1673 | \$1,672.21 |
| 06/15/2021 | Transfer Deposit From DDA XXXXXX1673 | \$60,665.89 |
| 06/18/2021 | Transfer Deposit From DDA XXXXXX1673 | \$26,274.98 |
| 06/21/2021 | Transfer Deposit From DDA XXXXXX1673 | \$94,532.76 |

2010 N. Ankeny Blvd.
Ankeny, IA 50023

PUBLIC FUNDS CHECKING-7021682 (continued)

Deposits (continued)

| Date | Description | Amount |
|------------|---|--------------|
| 06/22/2021 | Transfer Deposit From DDA XXXXXX1673 | \$243,054.99 |
| 06/25/2021 | Transfer Deposit From DDA XXXXXX1673 | \$182,572.76 |
| 06/30/2021 | Accr Earning Pymt Added to Account | \$18,981.51 |

Other Debits

| Date | Description | Amount |
|------------|--|--------------|
| 06/03/2021 | Transfer Withdrawal To DDA XXXXXX1673 | \$12,166.07 |
| 06/14/2021 | Transfer Withdrawal To DDA XXXXXX1673 | \$453,738.01 |
| 06/16/2021 | Transfer Withdrawal To DDA XXXXXX1673 | \$86,570.28 |
| 06/17/2021 | Transfer Withdrawal To DDA XXXXXX1673 | \$242,453.87 |
| 06/23/2021 | Transfer Withdrawal To DDA XXXXXX1673 | \$602,956.62 |
| 06/24/2021 | Transfer Withdrawal To DDA XXXXXX1673 | \$196,948.28 |
| 06/28/2021 | Transfer Withdrawal To DDA XXXXXX1673 | \$129,249.45 |
| 06/29/2021 | Transfer Withdrawal To DDA XXXXXX1673 | \$69,823.84 |
| 06/30/2021 | Transfer Withdrawal To DDA XXXXXX1673 | \$2,370.26 |

Daily Balances

| Date | Amount | Date | Amount | Date | Amount |
|------------|-----------------|------------|-----------------|------------|-----------------|
| 06/01/2021 | \$28,217,347.85 | 06/11/2021 | \$30,570,122.83 | 06/23/2021 | \$29,608,932.67 |
| 06/02/2021 | \$30,328,716.57 | 06/14/2021 | \$30,116,384.82 | 06/24/2021 | \$29,411,984.39 |
| 06/03/2021 | \$30,316,550.50 | 06/15/2021 | \$30,177,050.71 | 06/25/2021 | \$29,594,557.15 |
| 06/04/2021 | \$30,342,085.47 | 06/16/2021 | \$30,090,480.43 | 06/28/2021 | \$29,465,307.70 |
| 06/07/2021 | \$30,345,913.35 | 06/17/2021 | \$29,848,026.56 | 06/29/2021 | \$29,395,483.86 |
| 06/08/2021 | \$30,508,107.86 | 06/18/2021 | \$29,874,301.54 | 06/30/2021 | \$29,412,095.11 |
| 06/09/2021 | \$30,534,417.91 | 06/21/2021 | \$29,968,834.30 | | |
| 06/10/2021 | \$30,568,450.62 | 06/22/2021 | \$30,211,889.29 | | |

Overdraft and Returned Item Fees

| | Total for this period | Total year-to-date |
|--------------------------|-----------------------|--------------------|
| Total Overdraft Fees | \$0.00 | \$0.00 |
| Total Returned Item Fees | \$0.00 | \$0.00 |

RETURN SERVICE REQUESTED

CITY OF WEBSTER CITY
WC USDA REVOLVING LOAN
400 SECOND ST
PO BOX 217
WEBSTER CITY IA 50595-0217

Managing Your Accounts

-  Customer Service (515)832-1133
-  Telephone Banking (800)260-8419
-  Mailing Address 635 1st Street
Webster City, IA 50595
-  Online Banking www.availa.bank

Summary of Accounts

| Account Type | Account Number | Ending Balance |
|-----------------------|----------------|----------------|
| PUBLIC FUNDS CHECKING | 7025498 | \$184,131.37 |

PUBLIC FUNDS CHECKING-7025498

Account Summary

| Date | Description | Amount |
|------------|--------------------------|---------------------|
| 06/01/2021 | Beginning Balance | \$181,056.55 |
| | 2 Credit(s) This Period | \$3,074.82 |
| | 0 Debit(s) This Period | \$0.00 |
| 06/30/2021 | Ending Balance | \$184,131.37 |

Interest Summary

| Description | Amount |
|--------------------------------|--------------|
| Annual Percentage Yield Earned | 0.50% |
| Interest Days | 30 |
| Interest Earned Not Paid | \$0.00 |
| Interest Paid This Period | \$74.82 |
| Interest Paid Year-to-Date | \$432.48 |
| Minimum Balance | \$181,056.55 |

Deposits

| Date | Description | Amount |
|------------|---------------------------------------|---------|
| 06/30/2021 | Accr Earning Pymt Added to Account | \$74.82 |

Electronic Credits

| Date | Description | Amount |
|------------|---|------------|
| 06/21/2021 | ACH Deposit CITY OF WEBSTER USDA TRANS USDA TRANSFER | \$3,000.00 |

Daily Balances

| Date | Amount | Date | Amount | Date | Amount |
|------------|--------------|------------|--------------|------------|--------------|
| 06/01/2021 | \$181,056.55 | 06/21/2021 | \$184,056.55 | 06/30/2021 | \$184,131.37 |

Overdraft and Returned Item Fees

| | Total for this period | Total year-to-date |
|--------------------------|-----------------------|--------------------|
| Total Overdraft Fees | \$0.00 | \$0.00 |
| Total Returned Item Fees | \$0.00 | \$0.00 |

Report Criteria:

Print Outstanding Checks and Deposits and Bank and Book Adjustments

GENERAL CHECKING (GENERAL CHECKING) (1)
June 30, 2021

Account: 00110000

Bank Account Number: 7021673

| | | | |
|-------------------------|---------------|------------------------------|---------------|
| Bank Statement Balance: | 30,096,431.96 | Book Balance Previous Month: | 30,544,469.27 |
| Outstanding Deposits: | 23,384.32 | Total Receipts: | 2,889,049.74 |
| Outstanding Checks: | 620,003.02 | Total Disbursements: | 3,933,267.24 |
| Bank Adjustments: | 438.51 | Book Adjustments: | .00 |
| Bank Balance: | 29,500,251.77 | Book Balance: | 29,500,251.77 |

Outstanding Deposits

| Deposit Number | Deposit Amount | Deposit Number | Deposit Amount | Deposit Number | Deposit Amount | Deposit Number | Deposit Amount |
|----------------|----------------|----------------|----------------|----------------|----------------|----------------|----------------|
| 18 | 188.67 | 1244 | 1,869.85 | 1255 | 18,308.73 | | |
| 1184 | 100.00- | 1245 | 5.20 | 1256 | 3,111.87 | Total: | 23,384.32 |

Deposits cleared: 74 items Deposits Outstanding: 6 items

Outstanding Checks

| Check Number | Check Amount | Check Number | Check Amount | Check Number | Check Amount | Check Number | Check Amount |
|--------------|--------------|--------------|--------------|--------------|--------------|--------------|--------------|
| 11 | 559.90 | 2673 | 51.56 | 20579 | 75.00 | 51682 | 64.72 |
| 12 | 326,062.50 | 2676 | 55.41 | 20909 | 69.01 | 51691 | 16.30 |
| 13 | 620.91 | 2681 | 73.88 | 21362 | 21.47 | 51808 | 7.01 |
| 14 | 34.68 | 2682 | 716.13 | 21368 | 1.82 | 51842 | 45.58 |
| 15 | 30.15 | 2683 | 337.45 | 21796 | 46.03 | 52148 | 59.99 |
| 16 | 564.58 | 2691 | 175.24 | 50049 | 44.27 | 52249 | 7.28 |
| 1020 | 29.09 | 2692 | 72.74 | 50350 | 58.63 | 52296 | 74.44 |
| 1072 | 28.63 | 2695 | 255.01 | 50419 | 80.15 | 52555 | 32.31 |
| 1073 | 35.79 | 2697 | 65.00 | 50432 | 152.90 | 52557 | 25.00 |
| 1710 | 23.09 | 3754 | 55.41 | 50508 | 42.57 | 52814 | 88.87 |
| 1733 | 18.47 | 6804 | 28.63- | 50509 | 40.83 | 52900 | 29.62 |
| 1741 | 55.41 | 17532 | 247.00 | 50631 | 12.47 | 52934 | 54.42 |
| 1742 | 14.78 | 17542 | 97.12 | 50792 | 2.67 | 53208 | 111.27 |
| 1818 | 62.33 | 17791 | 64.67 | 50833 | 64.37 | 53242 | 13.59 |
| 1844 | 55.41 | 17939 | 1.86 | 50838 | 56.57 | 53285 | 6.00 |
| 1881 | 17.08 | 18050 | 71.73 | 50893 | 138.91 | 53306 | 72.35 |
| 1895 | 36.94 | 18333 | 49.48 | 50896 | 75.11 | 53452 | 34.78 |
| 1916 | 92.35 | 18616 | 2.25 | 50927 | 2.07 | 53534 | 76.38 |
| 2563 | 16.16 | 18738 | 39.35 | 51131 | 40.29 | 53551 | 15.21 |
| 2566 | 175.16 | 18760 | 44.22 | 51172 | 28.13 | 53637 | 5.17 |
| 2577 | 110.82 | 18862 | 68.08 | 51447 | 16.00 | 53693 | 132.41 |
| 2620 | 18.47 | 19009 | 377.00 | 51583 | 163.26 | 53704 | 83.58 |
| 2624 | 96.26 | 19329 | 11.93 | 51589 | 243.78 | 53752 | 2.87 |
| 2644 | 119.32 | 20274 | 62.14 | 51590 | 24.73 | 53783 | 1.32 |
| 2646 | 18.47 | 20489 | 274.07 | 51592 | 48.15 | 53811 | 166.00 |
| 2650 | 184.73 | 20538 | 31.15 | 51595 | 10.11 | 53818 | 61,147.67 |
| 2651 | 36.94 | 20570 | 71.91 | 51601 | 18.75 | 53891 | 90.33 |

| Check Number | Check Amount | Check Number | Check Amount | Check Number | Check Amount | Check Number | Check Amount |
|--------------|--------------|--------------|--------------|--------------|--------------|--------------|--------------------------|
| 53921 | 136.62 | 54668 | 19.48 | 54789 | 50.00 | 54832 | 100.00 |
| 54138 | 21.48 | 54733 | 1,946.64 | 54800 | 18,945.92 | 54837 | 342.74 |
| 54342 | 131.26 | 54737 | 33.03 | 54802 | 2,802.81 | 54851 | 70.00 |
| 54356 | 81.74 | 54756 | 114.25 | 54811 | 75.00 | 54852 | 75.00 |
| 54408 | 135.49 | 54760 | 46.00 | 54814 | 189.00 | 54853 | 50.00 |
| 54425 | 132.94 | 54772 | 171.00 | 54816 | 112,929.11 | 54855 | 9.36 |
| 54429 | 118.65 | 54774 | 114.92 | 54818 | 128.55 | 54859 | 17,925.00 |
| 54487 | 686.32 | 54777 | 18.15 | 54824 | 142.46 | 54860 | 93,218.75 |
| 54543 | 12.63 | 54779 | 543.65 | 54827 | 144.84 | 701202 | 3,990.33 |
| 54552 | 220.00 | 54780 | 239.05 | 54828 | 500.00 | 843738 | 33,230.39 |
| 54636 | 8.00 | 54783 | 34.14 | 54829 | 75.00 | | |
| | | | | | | Total: | <u><u>620,003.02</u></u> |

Checks cleared: 378 items Checks Outstanding: 151 items

Bank Adjustments

| Description | Amount | Description | Amount |
|----------------|--------|----------------|----------------------|
| RETURNED CHECK | 365.51 | RETURNED CHECK | 73.00 |
| | | Total: | <u><u>438.51</u></u> |

Book Adjustments

No book adjustments found!

Report Criteria:

Print Outstanding Checks and Deposits and Bank and Book Adjustments

**City of Webster City - Receipts
JUNE, 2021**

| <u>FUND</u> | <u>AMOUNT</u> |
|-----------------------|------------------------------|
| GENERAL FUND | \$197,460.42 |
| ROAD USE TAX FUND | \$105,642.62 |
| TIF | \$1,660.30 |
| SSMID | \$313.39 |
| SPECIAL REVENUE FUNDS | \$1,341,862.86 |
| DEBT SERVICE FUND | \$11,710.43 |
| FIDUCIARY FUNDS | \$386.31 |
| PERMANENT FUND | \$877.80 |
| IMPROVEMENT FUNDS | \$75,553.46 |
| ELECTRIC UTILITY FUND | \$1,795,279.36 |
| WATER UTILITY FUND | \$876,669.53 |
| SEWER UTILITY FUND | <u>\$666,079.00</u> |
| TOTAL | <u>\$5,073,495.48</u> |

City of Webster City
Summary of Investments - June 2021

| <u>Financial Institution</u> | <u>Investment</u> | <u>Term</u> | | <u>Purchase Date</u> | <u>Due Date</u> | <u>Redeem Date</u> | <u>Int Rate</u> | <u>Begin Balance</u> | <u>Purchased</u> | <u>Redeemed</u> | <u>Ending Balance</u> | <u>Month Interest</u> | <u>Interest YTD</u> |
|------------------------------|------------------------------|-------------|---------|----------------------|-----------------|--------------------|-----------------|----------------------|------------------|-----------------|-----------------------|-----------------------|---------------------|
| First State Bank | CD | 12 month | 3549930 | 08/14/19 | 08/14/20 | 08/14/20 | 2.12% | - | - | - | - | - | 42,516.16 |
| First State Bank | CD | 12 month | 3549698 | 06/19/20 | 06/20/20 | 07/07/20 | 2.45% | - | - | - | - | - | 24,567.12 |
| Availa Bank | CD-9 mo-purch-April 2021 | 9 month | 126597 | 04/10/21 | 01/10/22 | | | 507,619.45 | - | - | 507,619.45 | - | - |
| Peoples Credit Union | CD-6 mo purch March 2020 | 6 month | 2733 | 03/20/20 | 09/06/20 | 09/08/20 | 0.65% | - | - | - | - | - | 7,116.25 |
| Peoples Credit Union | CD-12 mo purch Sept 2019 | 12 month | 2734 | 09/19/20 | 09/06/20 | 09/08/20 | 2.35% | - | - | - | - | - | 23,601.75 |
| Peoples Credit Union | CD-12 mo purch Dec 2019 | 12 month | 2795 | 12/19/20 | 12/19/20 | 12/19/20 | 1.95% | - | - | - | - | - | - |
| Availa Bank | Sweep Account | | | | | | 0.77% | - | - | - | - | 18,981.51 | 274,092.74 |
| Availa Bank | USDA Revolving Loan Checking | | | | | | 0.50% | - | - | - | - | 74.82 | 824.76 |
| Availa Bank | Checking Account | | | | | | 0.50% | - | - | - | - | 205.48 | 2,496.57 |
| | | | | | | | | 507,619.45 | - | - | 507,619.45 | 19,261.81 | 375,215.35 |

1620 Superior Street Unit 1
Webster City, IA 50595
(515) 832-2885
(515) 832-2515 fax

Zachary S. Chizek
zach@groveslaw.net

Gary J. Groves
gary@groveslaw.net



GROVES & CHIZEK LAW OFFICE

July 28, 2021

TO: Members of the City Council

RE: Summary of Professional Services for July 2021

Dear Council Members:

Outlined below is a summary of professional services I have provided for the City of Webster City as City Attorney for the month of July 2021. The main issues I addressed this past month were (a) continued work on abandoned properties in town; and (b) handled a number of city citations, mainly related to animal ordinance issues.

In regards to abandoned properties, I have filed abandonment cases against two properties, 909 Harding Court and 1417 3rd Street. Both of these will go in front of a judge to determine if they are truly abandoned and if title should be transferred to the City to dispose of, as with previous abandonment cases. I am also going to be filing on 847 1st Street and also possibly 1033 Third Street in the near future. Both appear to be abandoned and in need of addressing.

Finally, in regards to other city citations, we have seen quite an uptick in City matters going in front of the court. Predominately they have revolved around animal ordinance violations, including animals at large, animal cruelty and vicious animals. I'm not sure what is causing the recent uptick in animal ordinance cases, but I'm hoping we begin to again see a decrease.

Respectfully submitted,

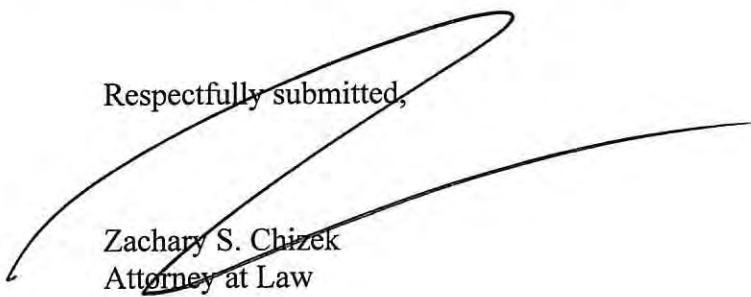

Zachary S. Chizek
Attorney at Law